

UNITED STATES PATENT AND TRADEMARK OFFICE

---

BEFORE THE PATENT TRIAL AND APPEAL BOARD

---

QUEST USA CORP.,  
Petitioner,

v.

POPSOCKETS LLC,  
Patent Owner.

---

Case IPR2018-00497  
Patent 8,560,031

---

Before CHRISTA P. ZADO, JESSICA C. KAISER, and  
STACY B. MARGOLIES, *Administrative Patent Judges*.

ZADO, *Administrative Patent Judge*.

FINAL WRITTEN DECISION  
*35 U.S.C. § 318(a)*  
*37 C.F.R. § 42.73*

## I. INTRODUCTION

We have authority to hear this *inter partes* review under 35 U.S.C. § 6. This Final Written Decision issues pursuant to 35 U.S.C. § 318(a) and 37 C.F.R. § 42.73. For the reasons discussed herein, we determine that Quest USA Corp (“Petitioner”)<sup>1</sup> has shown, by a preponderance of the evidence, that claims 9–11, 16, and 17 (“challenged claims”) of U.S. Patent No. 8,560,031 B2 (Ex. 1001, “the ’031 patent”) are unpatentable. *See* 35 U.S.C. § 316(e); 37 C.F.R. § 42.1(d)

### A. Procedural History

Petitioner filed a Petition for *inter partes* review of claims 9–11, 16, and 17 of the ’031 patent based on the following grounds: 1) claims 9–11, 16, and 17 as anticipated by Grinfas<sup>2</sup> under 35 U.S.C. § 102(b); 2) claims 9–11 as obvious over Grinfas under 35 U.S.C. § 103(a); 3) claim 9 as anticipated by Karmatz<sup>3</sup> under 35 U.S.C. § 102(e); 4) claims 9–11, 16, and 17 as obvious over the combination of Karmatz and Mikol<sup>4</sup> under 35 U.S.C. § 103(a); and 5) claim 9 as anticipated by Barbera<sup>5</sup> under 35 U.S.C.

---

<sup>1</sup> Petitioner identifies itself and Isaac Srour as real parties-in-interest in this proceeding pursuant to 37 C.F.R. § 42.8. Pet. 2.

<sup>2</sup> UK Patent Application GB 2 316 263 A (published Feb. 18, 1998). Ex. 1005 (“Grinfas”).

<sup>3</sup> Karmatz, U.S. Patent Publication No. 2012/0042476 A1 (filed Oct. 26, 2010, issued Feb. 23, 2012). Ex. 1006 (“Karmatz”).

<sup>4</sup> Mikol, U.S. Patent No. 4,927,191 (issued May 22, 1990). Ex. 1009 (“Mikol”).

<sup>5</sup> Barbera, U.S. Patent No. 2,876,979 (issued March 10, 1959). Ex. 1010 (“Barbera”).

§ 102(b). Paper 2, 6–7 (“Petition” or “Pet.”). PopSockets LLC (“Patent Owner”)<sup>6</sup> subsequently filed a Preliminary Response. Paper 6 (“Prelim. Resp.”). On August 13, 2018, the Board entered a decision on institution in which it determined Petitioner had shown a reasonable likelihood it would prevail in demonstrating claims 9, 10, 16, and 17 are anticipated by Grinfas. Paper 8, 19–29 (“Institution Decision” or “Inst. Dec.”). Because Petitioner had met the threshold for institution as to at least one claim, the Board instituted an *inter partes* review of all claims and all grounds presented in the Petition. *Id.* at 39.

After institution, Patent Owner filed concurrently a Response, Paper 16 (“Response” or “PO Resp.”),<sup>7</sup> and a Motion to File Under Seal and Enter Proposed Protective Order, seeking to file under seal sales information “submitted to establish commercial success of products embodying the patents under review,” Paper 22.<sup>8</sup> Petitioner thereafter filed a Reply to Patent Owner’s Response, Paper 30 (“Reply”), and an Opposition to Motion to File Under Seal and Enter Proposed Protective Order, Paper 20. Patent Owner filed a Reply re Motion to File Under Seal. Paper 27. Patent Owner

---

<sup>6</sup> Patent Owner identifies itself as the as real party in interest, pursuant to 37 C.F.R. § 42.8. Paper 3, 1.

<sup>7</sup> Patent Owner filed both a confidential (Paper 17) and redacted, non-confidential (Paper 16) version of its Response. For reasons discussed *infra*, Sec. II.E, this Final Decision need not, and does not, rely on or cite to information designated as confidential. Therefore, herein, we cite to the non-confidential version of Patent Owner’s Response.

<sup>8</sup> Patent Owner initially filed a motion to seal, Paper 15, but subsequently filed a corrected version of the motion, Paper 22. Herein, we cite to the corrected motion.

also filed a Sur-Reply to Petitioner's Reply to Patent Owner's Response. Paper 34 ("Sur-Reply").

Patent Owner also filed a Second Motion to File Under Seal, seeking to file under seal portions of the deposition transcript of Patent Owner's declarant, David Barnett. Paper 31. Petitioner filed an Opposition to Patent Owner's Second Motion to File Under Seal. Paper 36. Patent Owner filed a Reply for Second Motion to File Under Seal. Paper 38.

Petitioner also filed a Motion to Exclude Evidence Under 37 C.F.R. § 42.64(c), seeking to exclude exhibits, argument, and testing relating to tests performed by Mr. Barnett. Paper 40. Patent Owner filed an Opposition to Petitioner's Motion to Exclude Evidence. Paper 41. Petitioner filed a Reply to Patent Owner's Opposition to Motion to Exclude Evidence. Paper 43.

An oral hearing was held on May 9, 2018. A transcript of the hearing is included in the record. Paper 54 ("Tr.").

During the oral hearing, the Board raised questions concerning the scope and construction of the claim limitation "a cone shape constructed and arranged such that the walls fold generally parallel," as recited in claim 11 of the '031 patent. *See, e.g.*, Tr. 14:18–15:11, 16:21–19:21, 51:1–54:17. After the hearing, the Board decided it would benefit from further briefing concerning the definition of the term "cone," and ordered the parties to submit opening and responsive briefs regarding interpretation of the terms "cone" and "cone shape." Paper 48. Subsequent to the order, Petitioner filed an Opening Brief on the Scope and Construction of "Cone Shape," Paper 50, and Patent Owner filed an Opening Brief Regarding Board

Questions, Paper 52. Thereafter, Petitioner filed a Responsive Brief Regarding Board Questions, Paper 55, and Patent Owner filed a Responsive Brief Regarding Board Questions, Paper 57.

*B. The '031 Patent*

The '031 patent, titled “Extending Socket for Portable Media Player,” was filed on February 23, 2012. Ex. 1001, at [22]. The '031 claims priority to Provisional Application No. 61/453,375, filed March 16, 2011.

The '031 patent specification (“Specification”) describes extending sockets for attaching to the back of a portable media player or media player case. Ex. 1001, at [57]. The Specification’s Summary of Invention lists a number of purposes for the extending sockets, including

storing headphone cords and preventing the cords from tangling, forming stand legs, forming gaming grips, clipping to belts, waistbands and shirt pockets, forming legs for wedging [media] players that are phones between the shoulder and ear, and forming a grip that allows a user to securely hold and manipulate the [media] player with one hand.

*Id.* at 1:37–45. Figures 6–11 depict some of these uses of the extending sockets.

With respect to the embodiment depicted in Figures 1 through 3, “socket 24 generally comprises a collapsible accordion 2.” *Id.* at 4:44–45. Figure 3A is reproduced below.

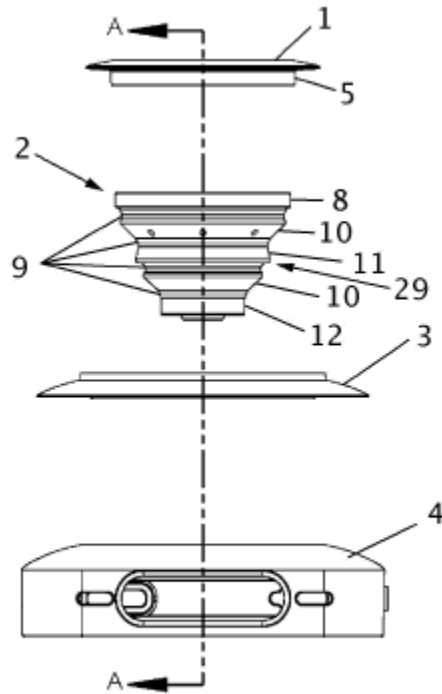

Figure 3A

*Id.* at Fig. 3A. Figure 3A illustrates a preferred embodiment of accordion 2 in its expanded configuration. Accordion 2 includes “a folding section 29 comprising a series of relatively rigid walls 10, 11, and 12 interspersed with flexural (or ‘living’) hinges 9, which flex as accordion 2 is collapsed or expanded.” *Id.* at 5:50–53. In this embodiment, “button 1 [is] attached to the distal end of accordion 2.” *Id.* at 4:46–47.

Figure 5 is reproduced below.

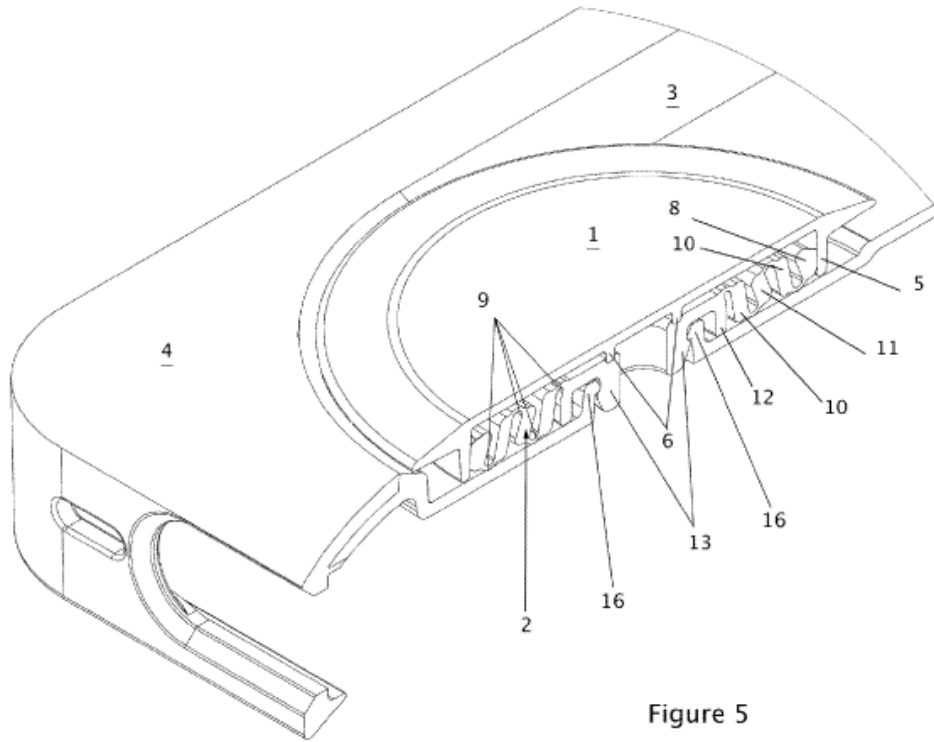
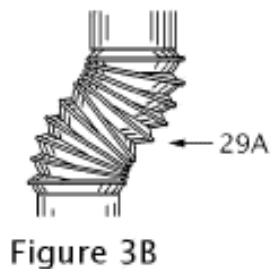

Figure 5

Figure 5 shows accordion 2 in its collapsed configuration. *Id.* at 6:7–10. In the collapsed configuration illustrated in Figure 5, the “flexing of hinges 9 allows walls 10 and 11 to fold up in a generally parallel configuration next to one another, rather than stacking on top of one another.” *Id.* at 6:11–13.

The Specification discloses an alternative accordion structure that allows “the buttons to extend not just straight outward from the case, but

also to curve away from the outward axis at various oblique angles.” *Id.* at 2:7–10. Figure 3B, reproduced below, depicts such a structure.



*Id.* at Fig. 3B. Figure 3B shows folding sections 29A comprising flexible membranes including hinges. *Id.* at 5:57–58. The Specification states that the structure in Figure 3A forms a cone that “allows walls 8, 10, 11, 12 to fold next to one another (as shown in FIG. 5) rather than stacking on top of one another as is the case with the embodiment of [Figure] 3B.” *Id.* at 5:58–63.

### C. *Related Cases*

According to the parties, Patent Owner has asserted the '031 patent against Petitioner in the following proceeding: *PopSockets LLC v. Quest USA Corp., et al.*, No. 1-17-cv-03653 (E.D.N.Y.) (filed June 16, 2017). Pet. 3, Paper 3, 1. Patent Owner contends the '031 patent has also been asserted in the following additional proceedings: *PopSockets LLC v. Digital Metro USA, Inc. d/b/a Wireless Stop and Akbar Tejani*, No. 3-17-cv-02398 (N.D. Tex.); *PopSockets LLC v. Gifttek™ LLC, et al.*, No. 8:17-cv-01825 (C.D. Cal.); *PopSockets LLC v. Craig Hueffner, Individual and d/b/a/ Absolute Marketing*, No. 2-17-cv-00827 (E.D. Wis.); and *In the Matter of Certain Collapsible Sockets For Mobile Electronic Devices And Components*

*Thereof*, Investigation No. 337-TA-1056 (U.S. Int’l Trade Comm’n).

Paper 3, 1–2. In addition, the ’031 patent is the subject of IPR2018-01294, instituted on January 23, 2019.

*D. Claims of the ’031 Patent*

Of the challenged claims, claims 9 and 16 are independent, and claims 10, 11, and 17 depend either from claim 9 or 16. Claims 9 and 16 are reproduced below (brackets and letters added):

9. A socket for attaching to a portable media player or to a portable media player case, comprising:

[a] a securing element for attaching the socket to the back of the portable media player or portable media player case; and

[b] an accordion forming a tapered shape connected to the securing element, the accordion capable of extending outward generally along its [axis] from the portable media player and retracting back toward the portable media player by collapsing generally along its axis; and

[c] a foot disposed at the distal end of the accordion.

16. A method comprising the steps of:

[a] attaching a socket including an accordion forming a tapered shape and having walls interspaced with flexural hinges to a portable media player;

[b] selectively extending the socket by unfolding the accordion generally along its axis; and

[c] selectively retracting the socket by folding the accordion generally along its axis such that the walls fold next to each other.

Ex. 1001, 7:60–8:4, 8:24–33, Certificate of Correction (correcting claim 9 as follows, “At Column 8, Line 1, ‘its from’ should be – its axis from --.”).

*E. Asserted Grounds of Unpatentability*

As we noted above, Petitioner asserts the following grounds of

unpatentability:

Claims 9–11, 16, and 17 as anticipated by Grinfas under 35 U.S.C. § 102(b);

Claims 9–11 as obvious over Grinfas under 35 U.S.C. § 103(a);

Claim 9 as anticipated by Karmatz under 35 U.S.C. § 102(e);

Claims 9–11, 16, and 17 as obvious over the combination of Karmatz and Mikol under 35 U.S.C. § 103(a); and

Claim 9 as anticipated by Barbera under 35 U.S.C. § 102(b).

Pet. 6–7.

To support its showing, Petitioner relies on the Declaration, Supplemental Declaration, and Second Supplemental Declaration of Glenn E. Vallee, Ph.D. *See* Ex. 1004; Ex. 1017; Ex. 1021.

## II. ANALYSIS

### A. *Legal Principles*

With regard to § 102, “[a]nticipation requires that every limitation of the claim in issue be disclosed, either expressly or under principles of inherency, in a single prior art reference,” *Corning Glass Works v. Sumitomo Elec. U.S.A., Inc.*, 868 F.2d 1251, 1255–56 (Fed. Cir. 1989), and that the claim limitations be “arranged or combined in the same way as recited in the claim[],” *Net MoneyIN, Inc. v. VeriSign, Inc.*, 545 F.3d 1359, 1371 (Fed. Cir. 2008). However, “the reference need not satisfy an *ipsissimis verbis* test.” *In re Gleave*, 560 F.3d 1331, 1334 (Fed. Cir. 2009). Anticipation under

§ 102 is a question of fact, including whether an element is inherent in the prior art. *Microsoft Corp. v. Biscotti, Inc.*, 878 F.3d 1052, 1068 (Fed. Cir. 2017); *Kennametal, Inc. v. Ingersoll Cutting Tool Co.*, 780 F.3d 1376, 1381 (Fed. Cir. 2015) (“Anticipation under 35 U.S.C. § 102 is a question of fact”); *In re Gleave*, 560 F.3d 1331, 1334–35 (Fed. Cir. 2009) (“After all, anticipation is a question of fact, including whether an element is inherent in the prior art.”).

With regard to § 103, issuance of a patent is forbidden when “the differences between the subject matter sought to be patented and the prior art are such that the subject matter as a whole would have been obvious at the time the invention was made to a person having ordinary skill in the art to which said subject matter pertains.” 35 U.S.C. § 103(a).

Under *In re Klein*, 647 F.3d 1343, 1348 (Fed. Cir. 2011), “[a] reference qualifies as prior art for an obviousness determination under § 103 only when it is analogous to the claimed invention.” “Two separate tests define the scope of analogous prior art”:

- (1) whether the art is from the same field of endeavor, regardless of the problem addressed and,
- (2) if the reference is not within the field of the inventor’s endeavor, whether the reference still is reasonably pertinent to the particular problem with which the invention is involved.

*Id.* (citations omitted). Whether a reference in the prior art is analogous is a question of fact. *In re Clay*, 966 F.2d 656, 658 (Fed. Cir. 1992).

*B. Level of Ordinary Skill in the Art*

Petitioner, citing the testimony of its declarant, Dr. Vallee, asserts that “[t]he prior art references show that a person of ordinary skill in the field, at

the time the '031 patent was effectively filed, would have either (1) five years or more of experience in mechanical product design, or (2) a bachelor's degree in Mechanical Engineering and one year or more of experience in mechanical product design." Pet. 8 (citing Ex. 1004 ¶ 26).

In the Preliminary Response, Patent Owner disagreed with Petitioner's assessment, and asserted

the Petition misstates the level of ordinary skill, and a person of ordinary skill would instead have: (a) a bachelor's degree in industrial design or mechanical engineering and at least one year of work experience in designing and assembling small, injection-molded components; or (b) in the alternative, would have at least three years of work experience in designing and assembling small, injection-molded components.

Prelim. Resp. 4. Patent Owner required, in particular, that the skilled artisan have experience designing and assembling small, injection-molded components. *Id.* Patent Owner did not provide the basis for its assessment of the level of ordinary skill in the art. The Specification does not mention injection-molding, nor make any reference to injection-molding components or manufacturing processes. For purposes of the Institution Decision, we adopted Petitioner's assessment of the level of ordinary skill in the art. Inst. Dec. 8–9. In the Response, Patent Owner states it does not dispute the Board's assessment in the Institution Decision of the level of ordinary skill in the art. PO Resp. 4. For purposes of this Final Decision, we adopt Petitioner's assessment, which Patent Owner does not contest.

### *C. Claim Construction*

In an *inter partes* review filed before November 13, 2018, claim terms in an unexpired patent are given their broadest reasonable construction in

light of the specification of the patent. 37 C.F.R. § 42.100(b).<sup>9</sup> Consistent with this standard, we assign claim terms their ordinary and customary meaning, as would be understood by one of ordinary skill in the art at the time of the invention, in the context of the entire patent disclosure. *See In re Translogic Tech., Inc.*, 504 F.3d 1249, 1257 (Fed. Cir. 2007). Only those terms that are in controversy need be construed, and only to the extent necessary to resolve the controversy. *See Nidec Motor Corp. v. Zhongshan Broad Ocean Motor Co.*, 868 F.3d 1013, 1017 (Fed. Cir. 2017) (citing *Vivid Techs., Inc. v. Am. Sci. & Eng'g, Inc.*, 200 F.3d 795, 803 (Fed. Cir. 1999)).

The Petition proposes constructions for the terms “socket,” “accordion,” “foot,” “flexural hinge,” “selectively extending,” and “selectively retracting.” Pet. 15–22. In the Institution Decision, we determined that, at that stage of the proceeding, no terms required express construction. Inst. Dec. 8. Patent Owner states that it disagrees with the constructions proposed in the Petition. PO Resp. 4. However, with the exception of the term “accordion,” Patent Owner does not provide any basis for its disagreement, or provide alternative proposed constructions for these terms. *Id.* Patent Owner asserts that express constructions of the following terms are required: “accordion,” “cone,” and “cone shape constructed and arranged such that the walls fold generally parallel.” *Id.*

---

<sup>9</sup> 77 Fed. Reg. 48727 (Aug. 14, 2012) (codified at 37 C.F.R. § 42.100(b)), as amended at 81 Fed. Reg. 18766 (Apr. 1, 2016); *see also* 83 Fed. Reg. 51340 (Oct. 11, 2018) (changing the standard for interpreting claims in *inter partes* reviews filed on or after November 13, 2018).

For purposes of this Decision, we interpret the terms “accordion,” “cone,” and “cone shape constructed and arranged such that the walls fold generally parallel.” We determine that no other terms require express construction.

1. “*accordion*”

a. *Introduction*

The following claim limitations are pertinent to discussion of the term “accordion”:

(claim 9) a socket for attaching to a portable media player or media player case, comprising “*an accordion forming a tapered shape connected to the securing element, the accordion capable of extending outward generally along its axis from the portable media player and retracing back toward the portable media player by collapsing generally along its axis,*” Ex. 1001, 7:60–61, 7:65–66, 8:1–3, Certificate of Correction (correcting claim 9 as follows, “At Column 8, Line 1, ‘its from’ should be – its axis from --”) (emphasis added); and

(claim 16) a method comprising the step of “*attaching a socket including an accordion forming a tapered shape and having walls interspaced with flexural hinges to a portable media player,*” *id.* at 8:25–28 (emphasis added).

The parties agree the term “accordion” should be construed according to its plain and ordinary meaning. PO Resp. 5; Reply 2. However, they disagree as to what is the plain and ordinary meaning. Patent Owner submits that the term “accordion” should be construed as “a tubular structure

with pleated folds.” PO Resp. 5 (emphasis omitted). Petitioner states that it disputes Patent Owner’s construction, but fails to state in the Reply what it contends is the term’s plain and ordinary meaning. Reply 1–2; 4–6.

In addition, the parties dispute whether the claims require a structure to be an “accordion” in all of the structure’s configurations, including when the structure is fully extended. *See, e.g.*, PO Resp. 26 (arguing that “[t]he challenged claims therefore require that the device be an *accordion* in the device’s expanded configuration” and must have “pleated folds in its expanded configuration,” and that the walls of the structure in Grinfas’s Figure 7A “lack the characteristic ‘zig-zag’ shape of accordion bellows”); Tr. 34:23–35:21 (Patent Owner’s counsel arguing that if the zig-zag shape is lost a structure that previously was an accordion no longer is an accordion).

Below we address both: 1) the meaning of “accordion,” and 2) whether the claims require a structure to have the zig-zag shape of accordion bellows in all states of extending and collapsing.

*b. Background*

In the Petition, Petitioner proposed to construe the term “accordion” as “a structure comprised of wall segments that fold parallel to its longitudinal axis.” Pet. 18. Patent Owner’s Preliminary Response proposed to construe the term as “a structure with pleated folds so as to collapse like the bellows of a musical accordion.” Prelim. Resp. 6. Among other things, Patent Owner cited the definition of “accordion” and the figure of a musical accordion from *Webster’s Third New International Dictionary*, reproduced below. *Id.*

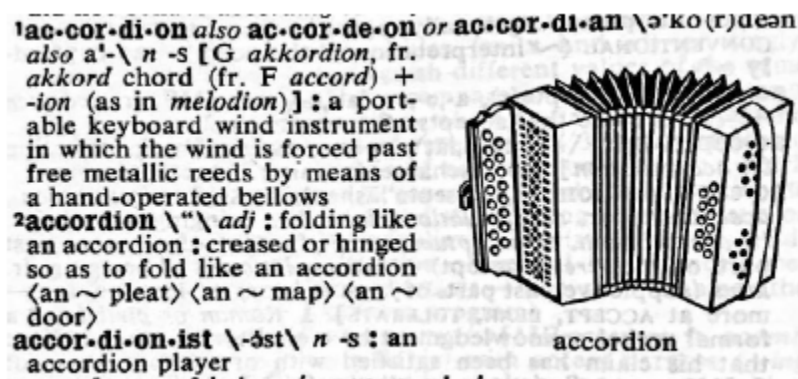

Ex. 1011, 2. As shown in the above reproduction, *Webster's Third New International Dictionary* defines “accordion” as “a portable keyboard wind instrument in which the wind is forced past free metallic reeds by means of a hand-operated bellows.” *Id.* The reproduction also includes a figure labeled “accordion” that illustrates a musical accordion having a keyboard on one-end, a flat structure on the other end with a strap for hand-operation, and bellows in-between.

In the Institution Decision, although we did not expressly construe the term “accordion,” we determined, based on the preliminary record, that the term “accordion” is not limited to structures like the musical accordion shown above, but rather includes the structures described as “accordions” in the '031 patent, such as accordion 2 shown in Figures 3A–B, reproduced below. Inst. Dec. 24–26.

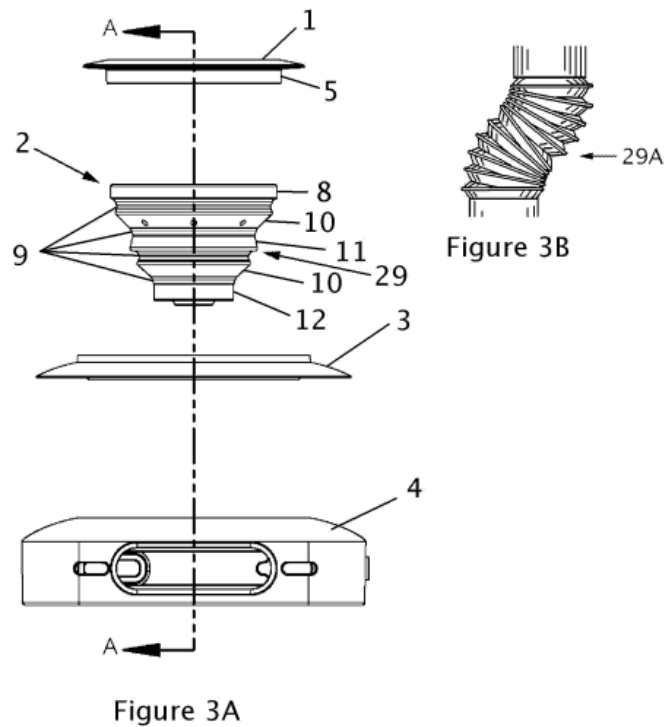

Ex. 1001, Figs. 3A–B. Figure 3A illustrates an exploded view of “a preferred embodiment of accordion 2 in detail.” *Id.* at 5:48–50. “[A]ccordion 2 includes a folding section 29 comprising a series of relatively rigid walls 10, 11, 12 interspersed with flexural (or ‘living’) hinges 9, which flex as accordion 2 is collapsed or expanded.” *Id.* at 5:50–53. Figure 3B illustrates an alternative folding section 29A of accordion 2. *Id.* at 5:56–67. “[F]olding sections 29A comprise[] flexible membranes including hinges.” *Id.* at 5:57–58. “In the embodiment of FIG. 3A, accordion 2 forms a cone. This allows walls 8, 10, 11, 12 to fold next to one another (as shown in FIG. 5) rather than stacking on top of one another as is the case with the embodiment of FIG. 3B.” *Id.* at 5:58–62. Figure 5 is reproduced below.

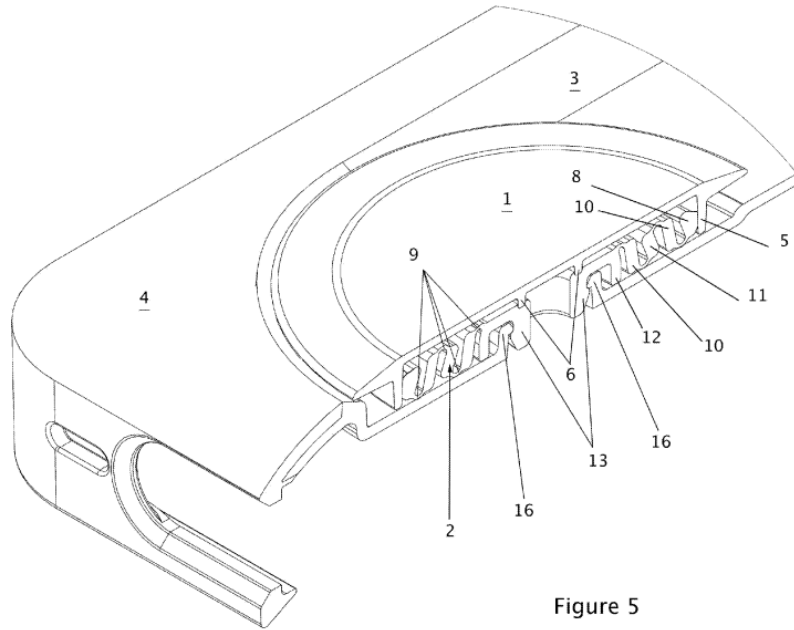

Figure 5

Ex. 1001, Fig. 5. Figure 5 depicts the accordion of Figure 3A in a collapsed configuration. *Id.* at 6:7–31. Flexing of hinges 9 allow walls 10 and 11 to fold up generally in parallel with each other, rather than stacking on top of one another as shown in Figure 3B. *Id.*

Based on these descriptions in the Specification, we determined on the preliminary record that the term “accordion” is not limited to accordion bellows, but rather it includes structures that have flexural hinges, as shown in Figures 3A and 5. Inst. Dec. 24–26.

Because we found sufficient evidence, for purposes of institution, that the structure disclosed in Figures 7A–B of Grinfas—relied on by Petitioner for disclosure of an “accordion”—includes flexural hinges that flex and fold, we determined that we did not need to further interpret the term “accordion.” *Id.* at 24–26.

*c. Meaning of “accordion”*

As we noted above, subsequent to institution, Patent Owner submitted that the term “accordion” should be construed according to its plain and ordinary meaning in the context of the ’031 patent as “a tubular structure with pleated folds.” PO Resp. 5 (emphasis omitted). In the Reply, Petitioner agreed we should give the term “accordion” its plain and ordinary meaning, but disputed Patent Owner’s position that it means “a tubular structure with pleated folds.” Reply 2. However, Petitioner failed to state in the Reply what it contends would have been the term’s plain and ordinary meaning. *See generally id.* at 1–2.

For reasons discussed below, we interpret the term “accordion,” consistent with the ’031 patent disclosure, as “a structure that has hinges, such as flexural hinges or flexural membranes, that fold so as to facilitate extending/expanding and collapsing of the accordion.”

*i. Intrinsic Evidence*

We agree with the parties that the term “accordion” should be given its plain and ordinary meaning as the term would have been understood by a person of ordinary skill in the context of the specification and prosecution history. The Specification does not provide any special definition for the term “accordion.” Absent any special definitions, we give claim terms their ordinary and customary meaning, as would have been understood by one of ordinary skill in the art at the time of the invention. *See Translogic*, 504 F.3d at 1257; *see also In re Paulsen*, 30 F.3d 1475, 1480 (Fed. Cir. 1994) (explaining that any special definitions for claim terms must be set forth with reasonable clarity, deliberateness, and precision).

Although the Specification does not define the term “accordion,” the Specification describes accordion structures, such as accordion 2. As we discussed above, Figures 3A–B illustrate two different accordion structures, both in extended configurations, and Figure 5A illustrates the accordion structure of Figure 3A in a collapsed configuration. The Specification describes accordion 2, with respect to these figures, as having flexural hinges or flexural membranes that include hinges that facilitate extending/expanding and collapsing the accordion. Ex. 1001, 5:50–53 (describing the accordion in Figure 3A as “includ[ing] a folding section 29 comprising a series of relatively rigid walls 10, 11, 12, interspersed with flexural (or ‘living’) hinges, which flex as accordion 2 is collapsed or expanded”); *id.* at 5:56–67 (describing the accordion in Figure 3B as having “[f]olding sections 29A compris[ing] flexible membranes including hinges”); *id.* at 6:7–16 (explaining with respect to the accordion in Figure 5 that “flexing of hinges 9 allows walls 10 and 11 to fold up in a generally parallel configuration next to one another, rather than stacking on top of one another . . . they are oriented diagonally upward when accordions 2 are extended and diagonally downward when accordions 2 are closed”). Therefore, consistent with the Specification, we interpret the term “accordion” as a structure that has hinges, such as flexural hinges or flexural membranes, that fold so as to facilitate extending/expanding and collapsing of the accordion.

We disagree with Patent Owner’s assertion that the intrinsic record supports its proposed construction. PO Resp. 5–11; Sur-reply 1–3. Patent Owner’s proposed claim construction—“a tubular structure with pleated

“folds”—requires us to replace the term actually used in the Specification, i.e., hinges, flexural hinges, and flexural membranes, with a term that is not used in the Specification. The Specification does not, anywhere, use the term “pleated folds.” Patent Owner’s basis for using this alternative language is that the Specification incorporates by reference U.S. Patent 2,094,268 (“the ’268 patent”) and U.S. Patent 4,846,510 (“the ’510 patent”), the latter of which “describes an accordion as a ‘pleated section that can be extended or contracted and angled,’ with ‘one or more pleats on one side of the body so as to can a part of the pleat to provide the angulation desired.’” PO Resp. 6–8 (citing Ex. 1001, 5:39–43; quoting Ex. 2015, 1:41–42, 2:31–34). The Specification incorporates the ’268 and ’510 patents in connection with the accordion structure shown in Figure 3B of the Specification, stating that as an alternative to the structure shown in Figure 3A, folding section 29 of the accordion “*could be configured similarly to the bendable portion of a bendable straw or Slinky® Pop Toob as shown in FIG. 38*” of the ’510 patent. *Id.* at 6 (citing Ex. 1001, 5:39–43) (emphasis added). The ’268 patent is entitled “Drinking Tube,” and depicts a bendable straw, which Patent Owner characterizes as having an accordion with pleated folds, but Patent Owner does not identify any disclosure in the ’268 patent indicating that such patent describes such structure as having “pleated folds.” *Id.* at 7.

Despite incorporation by reference of the ’268 and ’510 patents in connection with the accordion shown in Figure 3B of the Specification, the Specification nonetheless describes this accordion using the broader terminology “flexible membranes including hinges,” and nowhere uses the narrower term “pleated folds.” Ex. 1001, 5:56–58. Moreover, the structure

shown in Figure 3B is only one non-limiting embodiment of an accordion. Patent Owner fails to identify, nor do we discern, any disclosure in the intrinsic record that suggests any accordion in the '031 patent, other than that shown in Figure 3B, has “pleated folds.” Indeed, the accordion in Figures 3A and 5 are distinguishable from that of Figure 3B in that the latter shows wall segments that stack on top of one another, whereas Figures 3A and 5 show wall segments having flexible membranes including hinges that allow the wall segments to fold next to one another. *Id.* at 5:48–63. We discern no evidence that shows the flexibly hinged walls in Figures 3A and 5 would have been considered to have “pleated folds” like the flexible straws described in the '268 and '510 patents. Because an interpretation requiring “pleated folds” would exclude the embodiments shown in Figures 3A and 5, we decline to adopt such a construction. *Accent Packaging, Inc. v. Leggett & Platt, Inc.*, 707 F.3d 1318, 1326 (Fed. Cir. 2013) (stating that a claim construction “that excludes a preferred embodiment from the scope of the claim is rarely, if ever, correct”).

For the foregoing reasons, although the term “accordion” encompasses structures with pleated folds as shown in Figure 3B, which allow for walls to fold on top of each other in a collapsed configuration, the term is not limited to such structures.

Patent Owner argues that it is improper to construe “accordion” merely as a structure that includes flexural hinges, because non-accordion devices, such as food containers with hinged lids, are not accordions. PO Resp. 19–20. However, we do not construe the term “accordion” merely as any structure that includes flexural hinges. As we discussed above,

consistent with the Specification, we interpret the term “accordion” as a structure that has hinges, such as flexural hinges or flexural membranes, that fold *so as to facilitate extending/expanding and collapsing of the accordion*.

Patent Owner also argues that the mechanism for facilitating collapsing and expanding must be broader than “flexural hinges,” because “claim 9 recites an *accordion* but not *flexural hinges*,” whereas claim 10, depending from claim 9, recites flexural hinges. *Id.* at 20. Patent Owner draws the wrong conclusion. Claim 10 does not narrow the claim by merely requiring flexural hinges. Rather, claim 10 recites that the accordion comprise *rigid walls interspersed with flexural hinges*. Ex. 1001, 8:5–6. Moreover, Patent Owner has not explained sufficiently, nor do we discern, why the term “flexural hinges” would be a narrower, sub-category, of “pleated folds.” As we discussed above, the ’031 specification indicates the exact opposite—i.e., the term “flexural hinges” is applied more broadly than the term “pleated folds.”

Patent Owner also argues that a construction of “accordion” that includes the concept of expanding and collapsing would render superfluous the claim language reciting that the accordion is “capable of extending outwardly generally along its axis from the portable media player and retracting back toward the portable media player by collapsing generally along its axis,” as recited in claim 9. Sur-Reply 1–2. We disagree. Claim 9 does more than specify that the accordion has hinges that facilitate expanding and contracting, because it specifies that the extending and collapsing *must be generally along the accordion’s axis*. This claim requirement is consistent with the accordion in Figure 3A which shows

axis A along which the accordion expands and collapses. Ex. 1001, Fig. 3A. However, it is distinguishable from, for example, the accordion depicted in Figure 3B, in which the folding is depicted as allowing for expanding and collapsing the accordion in a manner that allows for bending but which does not necessarily require expanding and collapsing along the axis of the accordion. Ex. 1001, Fig. 3B. For the reasons stated above, we disagree that our interpretation of “accordion” would render the above-noted claim language superfluous.

The file history of the '031 patent does not alter our analysis. Patent Owner admits that “[t]he file history of the '031 patent does not address the construction of the term ‘accordion.’” PO Resp. 9. We agree with this assessment. As Patent Owner points out, the claims were amended to include the word “tapered shape” in order to distinguish the claimed accordion from the structure in a prior art reference relied on by the Examiner in an office action rejection. PO Resp. 9–10. However, this claim amendment does not bear on whether an accordion has hinges versus pleated folds.

For the foregoing reasons, we find that the intrinsic evidence supports interpreting “accordion” as “a structure that has hinges, such as flexural hinges or flexural membranes, that fold so as to facilitate extending/expanding and collapsing of the accordion.”

*ii. Extrinsic Evidence*

Patent Owner also relies on a figure in *Webster's Third New International Dictionary* illustrating a musical accordion to support its construction. PO Resp. 11–12. This is the same figure discussed above that

Patent Owner relied on in the Preliminary Response. Patent Owner asserts the musical instrument sense of “accordion” is consistent with the broadest reasonable interpretation of this term, in the context of the ’031 patent, without addressing or explaining how a musical accordion relates to the context of the ’031 patent. *See generally id.* As noted above, the dictionary defines the musical instrument sense of “accordion” as “a portable keyboard wind instrument in which the wind is forced past free metallic reeds by means of a hand-operated bellows.” Ex. 1011, 2. Patent Owner argues that the musical accordion in the dictionary figure is shown as having pleated folds, and therefore supports interpreting “accordion” to mean “a tubular structure having pleated folds.” PO Resp. 12. This definition and illustration of a musical instrument does not alter our interpretation of “accordion.”

Although extrinsic evidence like dictionaries may be considered, such evidence is generally of less significance than the intrinsic record. *Translogic*, 504 F. 3d at 1257. This single dictionary definition of a musical accordion does not outweigh the intrinsic evidence discussed above, *supra* Sec. II.C.1.c.i, especially because the sense of “accordion” as a musical instrument clearly is not the sense in which this term is used in the ’031 patent. *See, e.g.*, Ex. 1001, 1:45–48 (disclosing that extending sockets for portable media player cases “generally include extending elements, called ‘accordions,’ comprising cylindrical or conical membranes with flexural hinges having feet at their distal ends”). In addition, the structure of the musical accordion illustrated in the dictionary is dissimilar from the structure of accordion 2 embodied in Figure 3A and Figure 5 of the ’031

patent. As we discussed above, *supra* Sec. II.C.1.c.i, unlike the musical accordion in which wall segments fold on top of one another when collapsed, accordion 2 can be fully collapsed such that the wall segments of the accordion are generally parallel to each other, as illustrated by Figure 5 of the '031 patent. Accordion 2 includes hinges 9, which flex to allow walls 10 and 11, also shown in Figure 5, to fold up generally parallel to each other rather than folding on top of one another. Ex. 1001, 6:10–12. We must interpret the term “accordion” in the context of the disclosure such as the accordion embodied in Figure 5. Nothing in the intrinsic record indicates that the extrinsic evidence regarding a musical accordion should supersede the disclosure or context in which “accordion” is described and used in the '031 patent.

*iii. Conclusion as to the term “accordion”*

For the foregoing reasons, as we discussed above, consistent with the Specification, we interpret the term “accordion” as “a structure that has hinges, such as flexural hinges or flexural membranes, that fold so as to facilitate extending/expanding and collapsing of the accordion.” Moreover, we do not discern a basis to adopt a construction of “accordion” that uses the phrase “pleated folds,” as proposed by Patent Owner, in lieu of “hinges” to describe the mechanism that facilitates expanding and collapsing of an accordion.

*d. Whether the claims require a structure to have the zig-zag shape of an accordion bellows in all states of expanding and collapsing*

The parties also dispute whether the claims require an “accordion” to maintain pleated folds when in an expanded configuration. PO Resp. 26.

Patent Owner does not argue this requirement in its construction of the term “accordion.” *See generally id.* at 5–20. However, with regard to patentability, Patent Owner argues that Grinfas does not satisfy the claims because the structure in Grinfas “lack[s] the characteristic ‘zig-zag’ shape of accordion bellows; that is to say, they are linear, not pleated.” *Id.* at 26. In addition, during the hearing, Patent Owner’s counsel explained its position as to what a “pleated fold” is, namely that there “would be three walls, two folds arranged in the zig-zag shape.” *Id.* at 35:7–11. Patent Owner’s counsel explained further that a structure ceases to be an accordion if it loses the zig-zag shape when it is expanded, stating that “[i]f you lose the zig-zag shape it’s no longer an accordion because it’s no longer pleated.” *Id.* at 35:11–12.

The issue before us, therefore, is whether the claims require a structure in which the walls form a zig-zag shape of accordion bellows, and maintain such shape in an expanded configuration.

The phrase “zig-zag shape” is not used in the ’031 patent. Patent Owner does not precisely define what this phrase means in its claim construction discussion. However, Patent Owner sheds some light on what it means by “zig-zag” shape in its discussion of unpatentability, stating that Figure 7A of Grinfas “lack[s] the characteristic ‘zig-zag’ shape of accordion bellows; that is to say, they are linear, not pleated.” PO Resp. 26. Therefore, Patent Owner’s position is that “zig-zag” shape refers to bellows. Patent Owner identifies Figure 8A of Grinfas as showing a structure having “bellows.” Figure 8A is reproduced below.

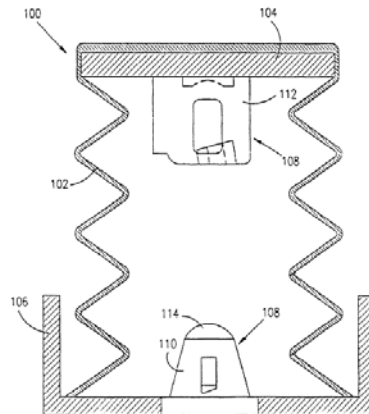

FIG. 8A

Ex. 1005, Fig. 8A. Figure 8A shows “a bellows type collapsible sound conduit 100,” having bellows 102 made of resilient material. *Id.* at 10:8–14. This structure is similar to the embodiment in Figure 3B of the ’031 patent, and the figure of the musical accordion in *Webster’s Third New International Dictionary*. PO Resp. 18 (citing Ex. 1011, 2); *see also supra* Sec. II.C.1.c.ii (reproducing the figure of a musical accordion in Ex. 1011, which is defined as having bellows). Namely, Figure 8A of Grinfas, Figure 3B of the ’031 patent, and the musical accordion figure, each shows a structure that has walls that fold on top of one another in a collapsed state. There is no dispute that all these figures depict accordions. However, it would be improper, in view of the accordions embodied in Figures 3A and 5 of the ’031 patent, to limit the interpretation of “accordion” to structures that have bellows as shown in Figure 8A of Grinfas, Figure 3B of the ’031 patent, and the musical accordion figure.

As we discussed above, in the collapsed state, as shown in Figure 5 of the ’031 patent, accordion 2 does not have bellows. As we noted above, the

bellows 1) shown in the dictionary defining a musical accordion, 2) shown in Figure 8A of Grinfas, and 3) shown in Figure 3B of the '031 patent, have walls that stack on top of one another in a collapsed configuration.

However, as shown in Figure 5 of the '031 patent, in the collapsed state the walls of accordion 2 fold generally parallel to each other. Patent Owner never addresses the fact that this structure does not comport with the figures depicting bellows. *See supra* Sec. II.C.1.c.

We also disagree with Patent Owner's argument that an "accordion" must maintain a bellows-like shape in a fully expanded configuration. Figure 3A of the '031 patent cannot be relied on for showing precise dimensions or angles of the hinges and walls of the accordion, and nothing in the Specification prohibits the walls of accordion 2 from being parallel to the accordion's vertical axis—i.e., not in a zig-zag shape—in an expanded state. We also note that to require an "accordion" to maintain a bellows-like shape in an expanded state, but not in a collapsed state, would be arbitrary. As we discussed above, in the collapsed configuration shown in Figure 5, the walls of accordion 2 fold generally parallel to each other, rather than on top of each other like the structures comprising bellows similar to those of a musical accordion.

For the foregoing reasons, we reject Patent Owner's argument that an "accordion" must have zig-zags in the shape of a bellows, and that the claims require the "accordion" to maintain zig-zags in the shape of a bellows in an expanded state.

2. “*cone*” and “*cone shape constructed and arranged such that the walls fold generally parallel*”

The following claim limitation is pertinent to discussion of the terms “cone” and “cone shape constructed and arranged such that the walls fold generally parallel”:

(claim 11) depending from claim 9 and reciting “*the tapered shape [of the accordion] comprises a cone shape constructed and arranged such that the walls fold generally parallel to the axis of the accordion when the accordion is collapsed.*” Ex. 1001, 8:7–11 (emphasis added).

Both parties agree that the ’031 patent does not apply any special definition to the term “cone,” and that this term should be accorded its plain and ordinary meaning. PO Resp. 21–22; Reply 2–3. However, the parties disagree as to what the plain and ordinary meaning would have been to an ordinarily skilled artisan in the field of the ’031 patent. The central dispute is whether the term “cone” is limited to circular cones, i.e., cones having a circular base and circular-cross sections, or whether it encompasses cones having non-circular, e.g., square, bases and cross-sections.

Patent Owner asserts that “cone” should be construed as “a tapered structure having a circular base and circular cross-sections along its axis.” PO Resp. 21–22. Figure 4 of the Second Supplemental Declaration of Dr. Glenn E. Vallee, Ph.D., P.E., Ex. 1021 (“Dr. Vallee’s Second Supplemental Declaration”) illustrates a circular cone.

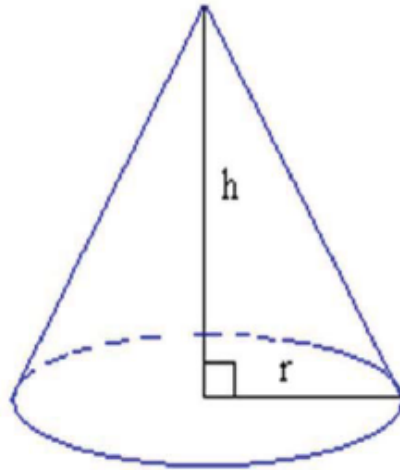

**Figure 4 – Right Circular Cone**

Ex. 1021 ¶ 8 (Fig. 4). Figure 4 shows a right circular cone with a circular base of radius “r” and height “h.” As can be seen from the figure, the horizontal cross-sections of the cone are circular.

Petitioner contends that the plain and ordinary meaning of the term “cone” would have encompassed structures having non-circular, such as square, bases and cross-sections. Reply 2–3; *see also* Ex. 1004 ¶ 73 (asserting that a cone may have a square base). Petitioner identifies square traffic cones as a real-world example of non-circular cones. Ex. 1019; Ex. 1020. An image of a square traffic cone is reproduced below.



Ex. 1020. The image in Exhibit 1020 purports to be from a retail website, Amazon.com, and shows a traffic safety cone that has a square base and square cross-sections. The description of the cone states that “Imperial Standard cones work well as traffic cones, safety cones, construction cones, parking cones, street cones, caution cones, and more.” *Id.*

Based on the dispute between the parties, namely whether a cone may have a non-circular base and non-circular cross-sections, we need not, and do not, construe expressly the term “cone” beyond determining whether this term would have encompassed structures having non-circular, such as square, bases and cross-sections.

With regard to the term “cone shape constructed and arranged such that the walls fold generally parallel,” Patent Owner argues this should be construed as “a tapered tubular structure having a circular base and circular cross-sections along its axis with walls having circular cross-sections that fold generally parallel.” PO Resp. 23–24. Petitioner responds that Patent

Owner's proposal simply restates Patent Owner's construction of "cone" and notes that the claim language recites that the walls fold generally parallel. Reply 3. Petitioner argues that this lengthier claim term does not require additional construction, and that the plain and ordinary meaning should apply. *Id.* We agree with Petitioner that the lengthier claim phrase does not, in order to resolve a dispute in this proceeding, require express construction. Accordingly, beyond our determination of whether the term "cone" would have encompassed structures having non-circular bases and cross-sections, we do not further construe expressly the term "cone shape constructed and arranged such that the walls fold generally parallel."

Prior to the oral hearing, the parties provided little evidence regarding the plain and ordinary meaning of the term "cone." Patent Owner relied in the Response on a preferred embodiment in the '031 patent that depicts accordion 2 as having a circular base and circular cross sections. PO Resp. 21. Patent Owner argued, for example, that the plain and ordinary meaning of "cone" "is evident in the '031 Patent, which states that, '[i]n the embodiment of Fig. 3A, accordion 2 forms a cone,' and depicts a cone-shaped accordion" as having a circular base. *Id.* Patent Owner argued further that the '031 patent does not disclose any embodiments of cones having non-circular bases and cross-sections. *Id.* Patent Owner's declarant, Dr. Babcock, did not provide any further basis for this construction of a "cone." *Id.* (citing Ex. 2018 ¶ 65). He concluded that the plain and ordinary meaning of "cone" is apparent from review of the '031 patent, and identifies only the embodiment shown in Figure 3A of the Specification. Ex. 2018 ¶¶ 65–66. He did not provide any other basis for his assertion that the plain

and ordinary meaning of the term “cone” is limited to circular structures.

*See generally id.*

In the Reply, Petitioner provided evidence that the term “cone,” as understood by a person of ordinary skill in the art, would have included structures with non-circular bases and non-circular cross-sections. Reply 3. Petitioner’s declarant, Dr. Vallee, asserted that square cones, in an engineering sense, were well-known in the art. *Id.* (citing Ex. 2019:19–25). Dr. Vallee provided a real-world example of a square cone, namely a traffic cone. *Id.* (citing Ex. 2019, 58:1–8). Petitioner argued further that this understanding is consistent with the ’031 patent’s disclosure, which nowhere suggests that the term “cone” is being used in a mathematical sense that limits it to having a circular base and cross-sections. *Id.*; *see also* Ex. 1004 ¶ 73 (Dr. Vallee’s declaration submitted with the Petition, asserting that a cone may have a square base).

During the oral hearing, Patent Owner’s counsel asserted that “the definition of a cone is what all of us understand a cone is, is that it would have a circular base,” but he did not cite any argument or evidence of record to support such understanding other than the preferred embodiment in the Specification showing a circular cone. Tr. 51:1–54:17. Petitioner’s counsel did not cite to any evidence to support the understanding that a cone could have a square base, other than Dr. Vallee’s testimony and the example of a square traffic cone. *See id.* at 14:25–15:11, 16:21–19:21.

After counsel for Patent Owner’s statement that “all of us understand what a cone is, is that it would have a circular base,” the Board took notice of, and entered into the record, a general dictionary definition of “cone”

during the hearing, which defines a cone as “a solid bounded by a circular *or other* closed plane base and the surface formed by line segments joining every point of the boundary of the base to a common vertex,” and noted there is, therefore, at least one dictionary definition of “cone” that does not limit “cone” to having a circular base. *Id.* at 52:5–19, 53:19–22 (emphasis added). Counsel for each party had the opportunity to respond to this definition at the oral hearing. *See generally id.* at 52:14–54:17 (Patent Owner’s counsel); *see generally id.* at 54:22–58:16 (Petitioner’s counsel’s rebuttal). In addition, subsequent to the hearing, the Board entered into the record Exhibit 3001 providing the above-discussed dictionary definition from *Merriam Webster’s Collegiate Dictionary*, which defines “cone” as follows:

1 a: a solid generated by rotating a right triangle about one of its legs—called also *right circular cone* b: a solid bounded by a circular or other closed plane base and the surface formed by line segments joining every point of the boundary of the base to a common base vertex—see VOLUME table c: a surface traced by a moving straight line passing through a fixed vertex.

Ex. 3001, 241 (“*Merriam Webster’s*”).

The Board also, after the hearing, ordered briefing from the parties regarding the construction of the term “cone” with regard to the following questions:

1. Whether the definition of “cone” as “a solid bounded by a circular or other closed plane base and the surface formed by line segments joining every point of the boundary of the base to a common vertex” (Ex. 3001) reflects the ordinary and customary meaning of “cone” to one of ordinary skill in the art of the ’031 patent.

2. Whether the intrinsic evidence of record limits the broadest reasonable interpretation of “cone shape” as recited in claim 11 to a shape with a base that is circular or whether that term includes a shape with a non-circular base.

3. Whether the dictionary definitions of “cone” in Ex. 3001, including “a solid bounded by a circular or other closed plane base and the surface formed by line segments joining every point of the boundary of the base to a common vertex,” affects the party’s contentions as to the broadest reasonable interpretation of “cone shape” as recited in claim 11.

Paper 48, 2–3. Pursuant to our order, each party filed an opening brief and a responsive brief. *Id.*; *see also* Paper 50 (Petitioner’s Opening Brief); Paper 52 (Patent Owner’s Opening Brief); Paper 55 (Petitioner’s Response to Patent Owner’s Opening Brief); Paper 57 (Patent Owner’s Response to Petitioner’s Opening Brief). The parties did not request further briefing or oral argument regarding the construction of “cone.” Accordingly, the parties were given a full opportunity to address Exhibit 3001 and to address the definition of the term “cone.”

*a. Intrinsic Evidence*

As we noted above, the parties assert, and we agree, that the term “cone” is not given any special definition in the Specification, and should be given its plain and ordinary meaning. Reply 2–3; PO Resp. 20–23. The Specification uses the term “cone” only three times, and the term “conical” once. Ex. 1001, 1:45–48, 2:12–17, 5:58–62, 6:23–31. In no instance is the term “cone” limited expressly to a circular cone in the Specification. To the

extent the Specification describes any feature of a cone, the Specification explains that it allows for the walls of the accordion to fold next to one another, as shown in the embodiment of Figure 5 of the of the Specification, as opposed to stacking on top of one another, as shown in the embodiment of Figure 3B. *Id.*

The Specification's Summary of Invention states that sockets, extendable outward from a portable media player case, "generally include extending elements, called 'accordions,' comprising cylindrical or conical membranes with flexural hinges having feet at their distal ends." *Id.* at 1:44–48. The summary of invention also describes an accordion having flexural hinges interspersed with walls, wherein "in at least one embodiment the accordions form cones having rotating 'flipper' walls as well as fixed walls that jointly result in the walls folding down next to one another (such that the walls are generally parallel to the axis of the accordion) rather than stacking on top of one another." *Id.* at 2:6–17. Absent from this description is any mention of the base and/or cross-section shape of the cone. The detailed description of the invention states, with regard to Figure 3A, "accordion 2 forms a cone," which "allows walls 8, 10, 11, 12 to fold next to one another (as shown in FIG. 5) rather than stacking on top of one another as is the case with the embodiment of FIG. 3B." *Id.* at 5:58–62. Although this particular embodiment is depicted in Figure 3A as having a circular base, nowhere does the Specification limit "cone" to structures with circular bases, or state that a circular base is what makes the accordion in Figure 3A a cone. Finally, the Specification states, with regard to accordion 2 depicted in Figure 5 (which is the same accordion of Figure 3A), "[i]n one

embodiment, accordion 2 is a cone formed of Skythane® S190A,” and describes flipper walls that allow “walls 8, 10, 11, 12 to fold next to one another in a generally parallel configuration.” *Id.* at 6:23–31. Again, although the accordion in this embodiment is depicted in Figure 5 as having a circular base, there is no express requirement that a “cone” is a structure with a circular base.

The only indication of the advantage of using a “cone” in the Specification, based on the above-noted disclosure, is that it allows walls to fold next to one another, rather than on top of one another, when flipper walls are present. *Id.* at 2:12–17, 5:58–62, 6:23–31. In comparing Figure 3A, in which walls fold next to one another, with Figure 3B, in which walls stack on top of one another, it is apparent that the smaller size of each cross-section as the accordion tapers along the accordion’s vertical axis facilitates walls folding next to each other. *Id.*; *see also id.* at Figs. 3A–B. The parties do not identify, nor do we discern, any disclosure indicating that the circular shape of the cross-sections facilitates walls folding next to one another. For the foregoing reasons, we do not discern any disclosure in the Specification indicating that the cross-sections must be circular or that the term “cone” was meant to limit the cross-sections to being circular.

Nor do we find anything in the file history of the ’031 patent that limits “cone” to circular cones. The term “cone” is in originally filed claim 11, Ex. 1003, 162, and we do not discern any discussion of the term “cone,” or any amendment, that limits the meaning of “cone,” *see generally id.* at 1–178.

Patent Owner's argument that the file history supports its interpretation is not availing. Applicant amended independent claim 9, from which claim 11 depends, to recite that the accordion forms a "tapered shape." *Id.* at 74. Patent Owner speculates that applicant and examiner agreed during a phone interview that restricting the claims to require the accordion to have a tapered shape distinguished the claims from Wang, which disclosed a non-tapered tube with a square base. *Id.*; *see also* Ex. 1003, 85–86 (request for interview by applicant). Patent Owner's reason for focusing on the limitation "tapered shape," rather than citing anything relating to the term "cone," appears to be based on Dr. Vallee's testimony that "cone" refers to a tapered shape. *See, e.g.*, PO Resp. 21. Patent Owner argues that interpreting "cone" to mean "any structure with a 'tapered shape'" would render the term "cone" superfluous because claim 9 already recites that the accordion has a tapered shape. *Id.* We do not construe "cone" to mean any structure having a tapered shape, so Patent Owner's argument is inapplicable.

Also, because there is no record in the file history that shows what was actually discussed during the interview, we do not speculate as to what was stated during the interview, much less whether Applicant and Examiner came to any agreement. *See generally* Ex. 1003. We note that during prosecution Applicant argued that the prior art reference at issue, Wang, disclosed an accordion that is not tapered and does not extend and retract generally along its axis. *Id.* at 73–76. In order to overcome Wang, Applicant amended the independent claims to include the recitation that the accordion is *tapered* and extends and retracts *generally along its axis*. *Id.* at

73–76. In its remarks accompanying the amendment, Applicant distinguished Wang, but said nothing about the term “cone.” *Id.* at 77–81. Furthermore, as noted above, the term “cone” is in original claim 11. *Id.* at 74. Therefore, the term “cone” was not added to the claim to overcome or distinguish Wang. For the foregoing reasons, nothing in the file history indicates an attempt to limit the term “cone” to circular cones.

Patent Owner’s identification of a circular cone shaped embodiment in the Specification does not indicate otherwise. PO Resp. 21. Patent Owner points out that none of the embodiments describe or show a non-circular cone shaped embodiment. However, nothing in the Specification or claim language limits “cone” to circular cones. We must be careful not to read a particular embodiment appearing in the patent specification into the claim if the claim language is broader than the embodiment. *See SuperGuide Corp. v. DirectTV Enterprises, Inc.*, 358 F.3d 870, 875 (Fed. Cir. 2004).

Based on the foregoing, the intrinsic evidence indicates that the broadest reasonable interpretation of the term “cone” is not limited to structures having a circular base and circular cross-sections.

*b. Extrinsic Evidence*

In determining the ordinary and customary meaning of “cone” as viewed by a person of ordinary skill in the art, it is appropriate to consult a general dictionary definition for guidance. *Comaper Corp. v. Antec, Inc.*, 596 F.3d 1343, 1348 (Fed. Cir. 2010). Although dictionary definitions provide context, to determine the “ordinary and customary meaning” of a term under the broadest reasonable interpretation standard, “claims must be

read in view of the specification, of which they are a part.” *Translogic*, 504 F. 3d at 1257 (quoting *Phillips v. AWH Corp.*, 415 F.3d 1303, 1315 (Fed. Cir. 2005) (en banc))).

The parties selectively cite dictionary definitions that they argue support their positions. Patent Owner, for example, quotes various dictionary definitions that provide mathematical and/or circular-based senses of the word “cone.” Paper 52, 2–3. In addition, Patent Owner argues that, where multiple senses, e.g., definitions, are provided for a word, the one listed first reflects the most commonly understood, primary meaning. *Id.* at 4. Patent Owner applies this rule without regard to the Specification. *Id.* at 2–4, 10. Petitioner cites an additional dictionary that defines “cone” similarly to definition 1b in *Merriam Webster’s*. Paper 50, 1 n. 1. We address the various cited dictionary definitions below.

Patent Owner asserts that definition 1b of *Merriam Webster’s* does not reflect the ordinary and customary meaning of “cone.” Paper 52, 2–4. Patent Owner premises this assertion on the argument that definition 1b is a secondary definition, rather than the primary definition, of the term “cone.” *Id.* To support the argument that definition 1b is a secondary definition, Patent Owner argues that, where there are alternative definitions or meanings of a word in a single dictionary, the first definition listed, i.e., definition 1a in *Merriam Webster’s*, typically reflects the “primary” meaning of the word. *Id.* at 3. Patent Owner cites no persuasive authority for the proposition that, in construing a claim term, the default definition to apply is the first definition listed amongst a list of alternative definitions. *See generally id.*

Petitioner points out that late Justice Antonin Scalia and Bryan A. Garner explain that, in consulting a dictionary, one must consult prefatory material in the dictionary to understand the principles upon which alternative definitions are ordered. Paper 55, 4 (citing Ex. 1024, 418). Scalia and Garner write “[a]lthough many people assume that the first sense listed in a dictionary is the ‘main’ sense, that is often quite untrue.” *Id.* (citing Ex. 1024, 418). *Merriam Webster’s* clarifies in its prefatory notes that the ordering of various senses of words does not indicate a hierarchy of importance, stating the following: “The system of separating the various senses of a word by numerals and letters is a lexical convenience. It reflects something of their semantic relationship, *but it does not evaluate senses or set up a hierarchy of importance among them.*” *Id.* at 4–5 (quoting Ex. 1025, 19a). Therefore, we place little weight on the ordering of the definitions in *Merriam Webster’s*.

To further support the argument that *Merriam Webster’s* definition 1a provides the ordinary and customary meaning of the term “cone,” Patent Owner also selectively provides definitions of cone from alternative dictionaries that Patent Owner asserts “only provide definitions for ‘cone’ that refer to structures with circular bases.” Paper 52, 2–3. Patent Owner identifies the *Cambridge Dictionary of American English*, which defines “cone” as “a solid shape with a round base that narrows to a point at the top, or any of various objects shaped like this, some of which are hollow and open at the end.” *Id.* at 2 (quoting Ex. 2105, 177). Patent Owner cites in a footnote four additional dictionary definitions. *Id.* at 2 n.2 (quoting Ex. 2106; Ex. 2107; Ex. 2108; Ex. 2109); *see also id.* at 3 (quoting an additional

definition of “cone” from Ex. 2110). Patent Owner also cites to the definition of “cone” in technical dictionaries, including the *Dictionary of Science and Technology* and *Machinery’s Handbook*. *Id.* at 3 (citing Ex. 2111; Ex. 2112). The former defines “cone” as “a solid body with a base in the shape of a circle, and with sides that narrow to a point.” *Id.* (quoting Ex. 2111). The latter provides equations for calculating the surface areas and volumes of cones, as distinguished from pyramids. *Id.* (citing Ex. 2112).

Patent Owner’s selective reliance on only the first-listed definition in several dictionaries is unpersuasive in showing that the non-circular aspect reflected in later-listed definitions should be excluded from the scope of “cone” or “cone shape.” Rather, these later-listed definitions further support a reading of the claims that does not exclude shapes with non-circular bases and cross-sections. For example, Patent Owner quotes the definition of “cone” in Exhibit 2110 as “any object or shape that has a circular base and tapers to a point at the top or has a circular top, and tapers to a point at the bottom.” Paper 52, 3 (citing Ex. 2110). However, this dictionary also defines “cone” as “a three-dimensional geometric figure formed by straight lines through a fixed point (vertex) to the points of a fixed curve (directrix). A circular cone has a directrix that is a circle,” Ex. 2110. This alternative definition expressly includes structures that have curved, non-circular bases, and even specifically distinguishes circular cones from other cones. *Id.*

Also, Patent Owner states that the *Dictionary of Science and Technology* defines “cone” as “a solid body with a base in the shape of a circle, and with sides that narrow to a point.” Paper 52, 3 (quoting Ex. 2111,

3). However, Patent Owner fails to quote in full the definition provided for this sense of the term “cone,” which states, “1. MATHS a solid body with a base in the shape of a circle, and with sides that narrow to a point,” and therefore provides strictly a mathematical definition. This dictionary provides another sense of “cone” that refers more generally to objects shaped like cones: “2. any object shaped like a cone.” Ex. 2111, 3.

Petitioner presents an additional dictionary that includes both a mathematical definition of “cone” similar to *Merriam Webster’s* definition 1a, but also includes a definition similar to 1b, defining “cone” as “a solid bounded by a circular or other closed plane base and the surface formed by line segments joining every point of the boundary of the base to a common vertex.” Paper 50, 1 n.1 (citing Ex. 1018).

The parties’ citations to dictionary definitions do not, alone, resolve whether plain and ordinary meaning would have encompassed non-circular cones. In applying the broadest reasonable interpretation, in view of the Specification and file history, we must first look to the intrinsic evidence. The Federal Circuit has stated that “[t]he specification ‘is the single best guide to the meaning of a disputed term.’” *Translogic*, 504 F.3d at 1257 (citations omitted). As we discussed above, applying the broadest reasonable interpretation of “cone” in light of the Specification, this term encompasses structures having a non-circular base and non-circular cross-sections. Although dictionary definitions may provide context, they do not replace the intrinsic record in ascertaining the broadest reasonable interpretation of a claim. The mathematical and/or circular-based definitions of “cone” quoted by Patent Owner are helpful in providing context. Such

definitions define a specific type of cone, namely a circular cone. Some of the dictionaries expressly distinguish circular cones from other cones. Ex. 2110 (distinguishing a circular cone, i.e., a cone having a circular directrix (i.e., base), from a cone having a non-circular directrix, providing that a cone has a fixed curve directrix, but a “[a] circular cone has a directrix that is a circle”); Ex. 3001, 241 (defining a circular cone, and stating “called also *right circular cone*”); *see also* Ex. 1018, 474. However, such definitions neither preclude the existence of other types of cones, i.e., non-circular cones, nor show that the plain and ordinary meaning of “cone” would have excluded non-circular cones. Indeed, as explained above, three of the dictionaries that provide circular cone definitions also provide non-circular cone definitions. Ex. 2110 (encompassing within “cone” structures having fixed-curve, non-circular bases); Ex. 3001, 241 (defining cone as a solid bound by a circular or other closed plane base); Ex. 1018, 474 (defining cone as a solid bound by a circular or other closed plane base). These definitions that provide for other, non-circular cones also provide relevant context, indicating that the plain and ordinary meaning of cone, consistent with the Specification, would have included non-circular cones. Patent Owner’s attempt to limit “cone” to mathematical and/or circular base senses is not required by the Specification, file history, or claim language, *see supra* Sec. II.C.2.a, and although Patent Owner’s proposed construction encompasses an embodiment in the Specification, it fails to provide for the broadest reasonable interpretation of claim 11.

We note that neither party’s evidence regarding traffic cones impacts our analysis. Dr. Vallee testifies that a cone, in the engineering sense of the

term, may have a square base, and furthermore, that a square traffic cone provides an example of square cone. *See* Ex. 2019, 57:17–58:11 (Dr. Vallee testifying that a square traffic cone provides an example of a cone in the engineering sense of the term); *see also* Ex. 1004 ¶ 73 (Dr. Vallee stating that a cone may have a square base). Neither Petitioner, nor Dr. Vallee, explain sufficiently why use of the term “cone” in the field of traffic safety would have indicated the plain and ordinary meaning of “cone” in the context of the ’031 patent. Ex. 2019, 57:17–58:11; Paper 50, 2–6. The field of invention of the ’031 patent states “[t]he present invention relates to extending sockets for portable media players.” Ex. 1001, 1:6–8. Dr. Vallee’s assertion that traffic cones provide an example of the “engineering” sense of the term “cone” is insufficient to explain how traffic safety cones indicate usage of the term “cone” in the context of the ’031 patent.

Patent Owner argues that the appropriate technical term for the square traffic cones in Exhibits 1019 and 1020 is “traffic pylons,” and that reference to them as “cones” is merely casual usage that does not bear on the meaning of “cone.” Paper 57, 3–4. Patent Owner argues further that Exhibits 1019 and 1020 do not correctly illustrate technical usage of the term “cone” even within the field of traffic-control devices, citing to a patent that Patent Owner argues distinguishes traffic cones from frusto-pyramidal structures. *Id.* at 4 (citing Ex. 2124, 3:1–3). However, Patent Owner’s arguments amount to attorney argument, unsupported by declaration testimony. Moreover, in arguing proper technical use of the term “traffic cone,” Patent Owner fails to mention, much less address, the numerous references to and/or definitions of traffic cone in the dictionaries it cites for the definition

of “cone.” Ex. 2106 (“(also traffic cone) a plastic cone-shaped object used to separate off sections of a road”); Ex. 2107 (“2 anything cone-shaped, such as a wafer holder for ice cream, a temporary marker for traffic on roads, etc.”); Ex. 2108 (“1 a hollow or solid object with a round base and a point at the top: *an orange traffic cone*”); Ex. 2109 (“2 an object of this [cone] shape: *an ice-cream cone: orange traffic cones along the side of the road*”); Ex. 2110 (“4. TRANSP PLASTIC CONE-SHAPED ROAD MARKER a plastic-cone shaped object used as a temporary road marker or barrier, e.g., to close off part or all of a road during repairs or after an accident”). With the exception of Ex. 2108, these definitions of, and/or references, to traffic cones describe them as being cone-shaped, without expressing either way whether cone-shaped is limited to circular cones. These definitions, therefore, require one to consult the definition of “cone,” and therefore do not provide additional helpful context.

For the foregoing reasons, the evidence and argument regarding square traffic cones does not impact our analysis.

Accordingly, we find that the extrinsic evidence, when viewed in light of the '031 patent and file history, is consistent with interpreting “cone” to include structures having non-circular bases and non-circular cross-sections.

*c. Conclusion*

For the foregoing reasons, we determine that the broadest reasonable interpretation of the terms “cone” and “cone shape constructed and arranged such that the walls fold generally parallel” is not limited to structures having circular bases and cross-sections, but rather includes structures that have other, non-circular shaped bases and cross-sections.

D. *Assertions of Unpatentability*

As we indicated above, Petitioner asserts the following grounds of unpatentability: claims 9–11, 16, and 17 as anticipated by Grinfas under 35 U.S.C. § 102(b); claims 9–11 as obvious over Grinfas under 35 U.S.C. § 103(a); claim 9 as anticipated by Karmatz under 35 U.S.C. § 102(e); claims 9–11, 16, and 17 as obvious over the combination of Karmatz and Mikol under 35 U.S.C. § 103(a); and claim 9 as anticipated by Barbera under 35 U.S.C. § 102(b). Pet. 6–7.

*1. Overview of Grinfas (Ex. 1005)*

Grinfas relates to a collapsible sound conduit for attaching to a cellular telephone. *Id.* at [57]. Grinfas states that a concern had arisen regarding the safety of users of portable hand-held cellular telephones, namely with regard to radiation emitted by such telephones. *Id.* at 1:8–11. To address such concern, Grinfas discloses a collapsible sound conduit placed between the telephone’s earpiece and the user’s ear, for enabling a user to maintain the telephone at a spaced distance away from the user’s head to reduce radiation exposure while nevertheless maintaining an acceptable level of hearing. *Id.* at 1:17–25. Figure 2 of Grinfas, reproduced below, illustrates an example of collapsible sound conduit. *Id.* at 4:9–11.



Grinfas discloses various embodiments of a collapsible sound conduit. “In a first embodiment, the collapsible sound conduit includes a plurality of telescoping sections.” *Id.* at 2:7–8. “In a second embodiment, the collapsible sound conduit includes a resilient portion which is collapsible and foldable into itself,” and may “further include a plurality of stiffeners” that may include ribs arranged to define an acoustical path and which may be adapted to limit collapsing of the conduit beyond a predetermined position. *Id.* at 2:12–19. “In a third embodiment, the collapsible sound conduit includes a bellows” that “may have a surface which is tiltable about a pivot.” *Id.* at 2:20–22. “In a fourth embodiment, the collapsible sound conduit includes a conduit pivotable about a pivot.” *Id.* at 2:23–24.

## 2. Overview of Karmatz (*Ex. 1006*)

Karmatz relates to an “apparatus for gripping a handheld device.” *Ex. 1007*, Abstract, ¶ 3. Karmatz states that the “use of handheld electronic devices such as Personal Digital Assistants (PDAs) and smartphones, has increased significantly.” *Id.* ¶ 5. According to Karmatz, the use of large touch-screen displays on such devices, “although allowing a user to easily access a large touch screen, may create difficulty for users to securely grip these devices with a single hand, which results in users frequently dropping and damaging their devices.” *Id.* ¶¶ 5–6. To address the issue of securely gripping these devices, Karmatz discloses “a finger grip apparatus for a handheld device.” *Id.* ¶ 11.

Figure 1 of Karmatz, reproduced below, illustrates “a conventional hand-held device gripped by a user’s hand.” *Id.* ¶ 14, Figs. 1A–B.

FIG. 1  
PRIOR ART

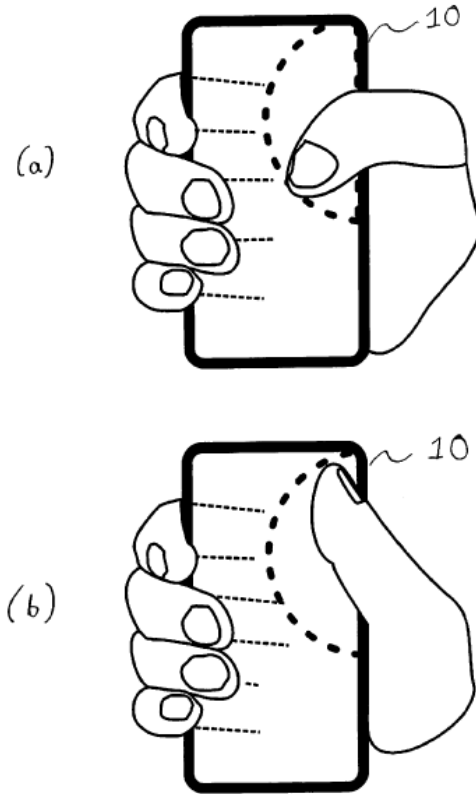

*Id.* at Figs. 1A–B. Figures 1A–B depict handheld device 10 being gripped by a user’s hand, and in particular, depict with a dotted line the range of motion of the user’s thumb on device 10’s touch screen. *Id.* ¶ 8. “In order to reach other areas of the front surface of the handheld device 10 with the user’s thumb, a user must either reposition the device with a similar grip . . . or a user must use a relaxed grip.” *Id.* ¶ 9. “In either case, a user must grip the handheld device 10 less securely and/or shift the handheld device 100 with respect to the user’s hand, in order for a user to access an entire range

of the front surface [] of the device with the user's thumb." *Id.* "Therefore, there is a need for an apparatus for securely holding devices [] with a single hand while allowing a greater range of movement of a user's fingers while holding the device." *Id.* ¶ 10.

Figure 3 of Karmatz illustrates "a grip device having a base integrated into a sleeve of a handheld device," and Figure 4 illustrates another embodiment of a grip device that "allows a user to rest fingertips along the back of the handheld device 140 instead of wrapping fingers around an entire back of the handheld device 140." *Id.* ¶¶ 16, 27, Figs. 3–4. Figure 4 is reproduced below.

FIG. 4

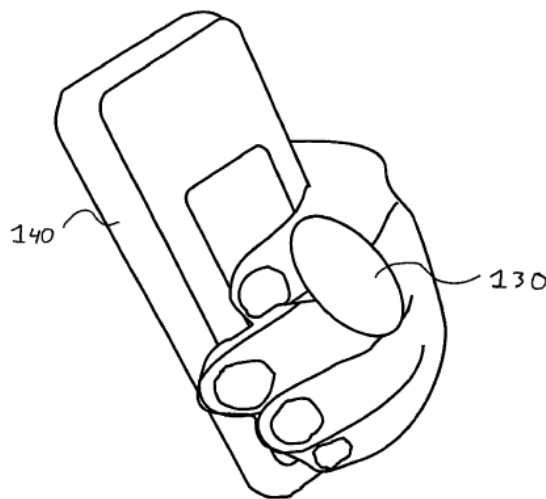

Ex. 1006, Fig. 4. Figure 4 depicts handheld device 140 with grip 130 attached thereto. *Id.* When device 140 "is a touch-screen device, the finger grip apparatus allows a user to rest fingertips along the back of the handheld device 140 instead of wrapping fingers around an entire back of the

handheld device 140.” *Id.* ¶ 27. The positioning shown in Figure 4 “allows a user’s thumb to more easily reach an entire range of a touch screen, thereby allowing a user to more easily operate a touch-screen device with a single hand.” *Id.* Figures 4–25 of Karmatz illustrate embodiments of various grip devices.

### *3. Overview of Mikol (Ex. 1009)*

Mikol generally relates to “an adjustable tubular wall structure for tubular connectors, conduits, containers, and the like, and more particularly, to a pleated tubular body that is extensible [and] [] contractible . . . both longitudinally and laterally . . . and [] may be angled relative to its central axis” for accommodating a connection between out of alignment discharge and intake ports, for example in the field of plumbing and installation of drain systems. Ex. 1009, 1:7–17, 7:45–46. Mikol relates also to “an adjustable, non-cylindrical wall structure, particularly designed for containers,” which is extensible and contractible, both longitudinally and laterally, may be angled relative to its central axis, may be contracted into a “nested” configuration, and is “particularly well adapted to serve as a pouring spout or other adjustable spout.” *Id.* at 1:18–27.

### *4. Overview of Barbera (Ex. 1010)*

Barbera relates generally to “devices for absorbing mechanical forces and more particularly to a unitary protective mount adapted both to isolate equipment supported thereby from shock impulses and to absorb vibratory disturbances.” Ex. 1010, 1:15–19. Barbera discloses that when an apparatus is rigidly attached to a surface or base, “disturbing mechanical forces imparted to the base will be transmitted to the apparatus.” *Id.* at 1:20–23.

According to Barbera, in order to minimize the effect of such disturbances, “it is known to introduce flexible elements or springs between the supporting base and the [apparatus] mounted thereon to act as a vibration insulator or isolator.” *Id.* at 1:27–30. Barbera discloses that characteristics of the flexible element or spring that provide for effective vibration isolation are incompatible with characteristics that provide effective shock absorption. *Id.* at 1:41–43. A “principal object” of Barbera, therefore, is “to provide a unitary mount acting both as a shock absorber and as a vibration isolator.” *Id.* at 1:49–51. “A significant feature of the invention resides in the use of air-cushioned bellows having a high degree of resiliency acting in cooperation with spring elements of low resiliency to afford protection both against shock and vibration and to provide dampening in all directions.” *Id.* at 1:56–61. Figure 1 of Barbera is reproduced below.

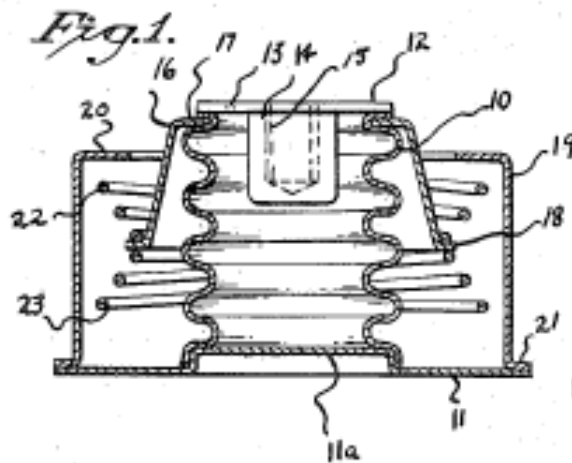

Ex. 1010, Fig. 1. Figure 1 illustrates a shock absorption and vibration isolator. *Id.* at 2:10–11. The shock absorption and vibration isolator includes cylindrical metal bellows 10 mounted and hermetically sealed on rectangular base plate 11. *Id.* at 2:12–16. “Secured to the upper end of the

bellows is a disc-shaped top plate 12 having a small orifice 13.” *Id.* at 2:16–18. “Thus the bellows constitute an air-tight enclosure except for the small orifice.” *Id.* at 2:18–19. Barbera discloses the following:

The metal bellows 10 responds in the manner of a helical spring operating in all directions, the flexibility of the bellows depending on the type of metal used, the wall thickness and the number of convolutions. Compression of the bellows will result in compressing the air contained therein, the air being slowly released through the small orifice to provide air damping of the bellows isolator in all directions. Forced vibrations will cause the metal bellows to have motion in the vertical, horizontal, and transverse directions. Rotation about these axes will cause the volume of air within the bellows to change, the air flowing in or out of the orifice. The work involved in forcing air through the orifice serves to convert some of the energy due to vibration, thereby attenuating the vibratory forces.

*Id.* at 2:50–64.

#### *5. Asserted Anticipation by Grinfas*

As we discussed above, Petitioner asserts claims 9–11, 16, and 17 are unpatentable as anticipated by Grinfas. Pet. 23–34; Reply 4–8. Patent Owner responds that Grinfas does not anticipate these claims because Grinfas does not disclose the following: 1) “a securing element for attaching the socket to the back of a portable media player or portable media player case,” 2) an “accordion forming a tapered shape connected to the securing element, the accordion capable of extending outward generally along its axis from the portable media player and retracting back toward the portable media player by collapsing generally along its axis,” and 3) “a cone shape constructed and arranged such that the walls fold generally parallel.” PO Resp. 24–33; Sur-Reply 5–11.

Grinfas is a UK patent application published on February 18, 1998. Ex. 1005, at [43]. Petitioner asserts Grinfas is prior art under 35 U.S.C. § 102(b). Pet. 5. Because Grinfas's publication date is more than one year before the filing of the earliest application to which the '031 patent claims priority, we determine that Grinfas is prior art under 35 U.S.C. § 102(b).

Moreover, for the reasons stated below, we determine Petitioner has demonstrated, by a preponderance of the evidence, that claims 9–11, 16, and 17 are unpatentable as anticipated by Grinfas.

*a. Claim 9*

Annotated Figures 7A–B of Grinfas illustrate Petitioner's assertions (annotations in red).

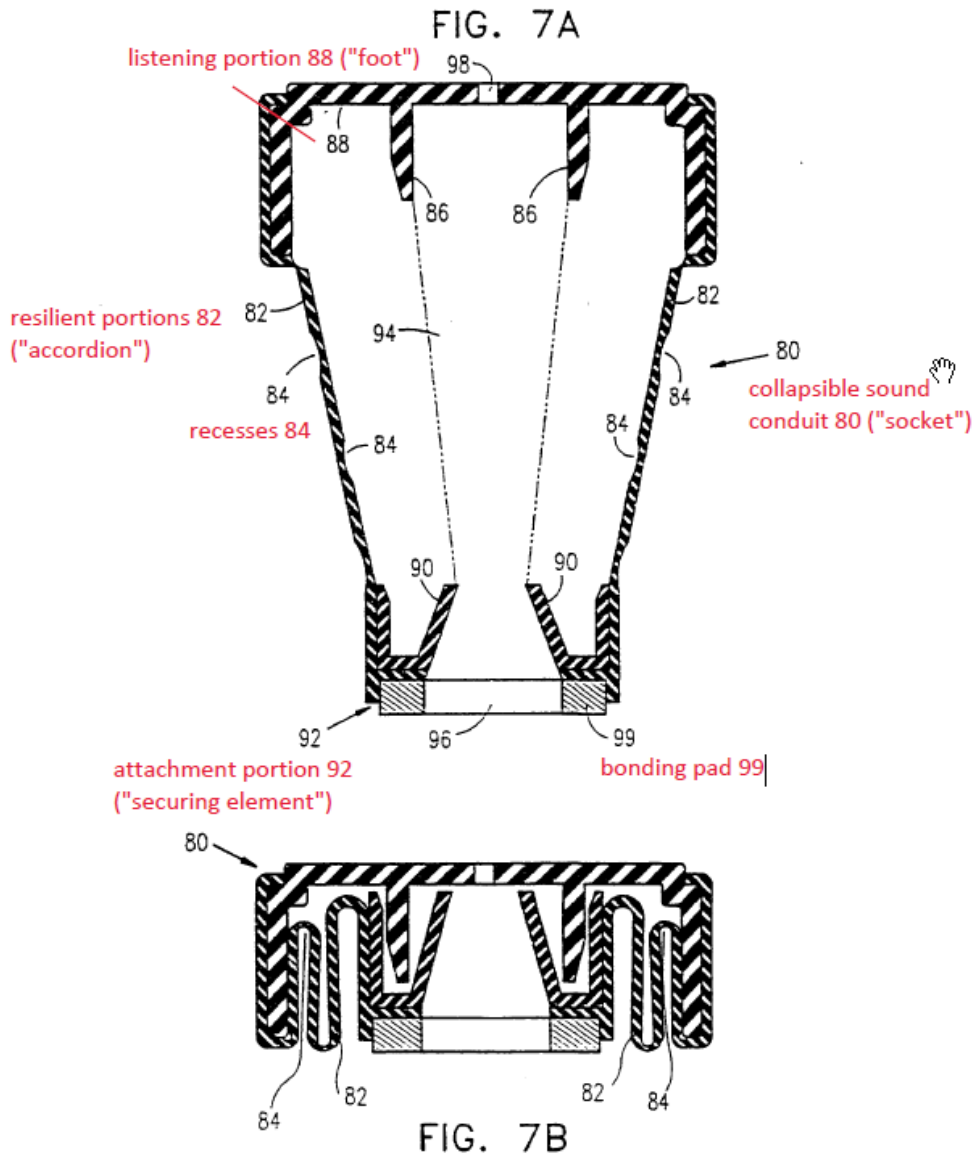

Ex. 1005, Figs. 7A–B. Grinfas’s Figures 7A and 7B show collapsible sound conduit 80 in expanded (7A) and collapsed (7B) configurations.

Petitioner identifies collapsible sound conduit 80 as the asserted socket for attaching to a portable media player or portable media player case. Pet. 23–25. Petitioner identifies attachment portion 92 as a securing element, *id.* at 25–26, which attaches sound conduit 80 to a telephone via

bonding pad 99, Ex. 1005, 10:6–7. Petitioner asserts that the walls of the sound conduit, i.e., resilient portions 82 (which are interspersed with recesses 84), comprise an accordion forming a tapered shape connected to the asserted securing element. Pet. 27. Petitioner argues that the asserted accordion is capable of extending outward generally along its axis from the telephone and retracting back toward the telephone by collapsing generally along its axis, as shown in Figures 7A–B, which depict the sound conduit in extended and collapsed configurations. *Id.* at 28. Finally, Petitioner identifies listening portion 88 as the asserted foot disposed at the distal end of the accordion. *Id.*

Patent Owner disputes Petitioner’s assertions that Grinfas discloses “a securing element” and “an accordion,” as those terms are used in the claim. PO Resp. 24–29; Sur-Reply 5–9. Patent Owner does not otherwise challenge Petitioner’s showing that Grinfas anticipates claim 9.

*i. Non-disputed claim recitations*

Petitioner persuasively shows that Grinfas discloses the preamble of claim 9, which recites a “socket for attaching to a portable media player or to a portable media player case.” Petitioner persuasively argues, and we agree, that Grinfas’s collapsible [sound] conduit 42, 52, 72, which attaches to cellular telephone 40, 50 or phone case 71, discloses a socket for attaching to a portable media player or portable media player case. Pet. 23.

Petitioner also persuasively shows that Grinfas discloses “a foot disposed at the distal end of the accordion,” as recited in claim 9. In the embodiments of the ’031 Specification, the distal end of the accordion is the end opposite the end with the securing element. *See* Ex. 1001, 4:47–48,

Fig. 1 (describing button 1 attached at the distal end of the accordion). As an example of a foot, the Specification discloses “buttons may snap onto the ends of the accordions, be glued on, or be feet integrally formed with the accordions.” *Id.* at 2:10–12. Petitioner argues that if the term “foot” is interpreted to mean the distal end of the accordion, the distal end of conduit 82 in Grinfas discloses a “foot.” Pet. 28. Petitioner argues that if “foot” must be a structure separate from the accordion, Grinfas’s user listening portion 88 at the end of conduit 82 discloses a foot. *Id.* We find that Grinfas’s distal end of conduit 82 discloses this claim limitation, which is consistent with the Specification’s exemplary foot disposed at the distal end of the accordion. Ex. 1001, 2:10–12.

ii. *“a securing element for attaching the socket to the back of the portable media player or portable media player case”*

With regard to claim 9’s recitation that the socket comprises “a securing element for attaching the socket to the back of the portable media player or portable media player case” (“securing element limitation”), there is no genuine dispute that Grinfas discloses the recited structure, namely “a securing element.” However, the parties dispute whether the remaining language, “for attaching the socket to the back of the portable media player or portable media player case,” recites 1) functional language that must be given patentable weight, or 2) an intended use that is not limiting. Patent Owner argues that the phrase “for attaching the socket to the back of the portable media player or portable media player case” recites functional language that must be given patentable weight. PO Resp. 28–29; Sur-Reply 7–9. Petitioner argues this language is not functional, but rather

recites an intended use, and as such, this language is not limiting. Reply 6–7. The parties also dispute whether the “for attaching” recitation is inherently disclosed in Grinfas. Pet. 25–26; Reply 6–7; PO Resp. 28–29; Sur-Reply 7–9.<sup>10</sup>

There is no genuine dispute, and we find, that Grinfas discloses the structure recited in claim 9, namely “a securing element.” Petitioner argues, and we agree, that Grinfas’s adhesive pad 46, straps 54, and telephone attachment portion 92 (collectively “securing structures”), each attach the asserted socket, i.e., collapsible sound conduit, to the asserted media player, i.e., a telephone. *Id.* at 25–26. Figures 3 and 4A of Grinfas, reproduced below, are illustrative.

---

<sup>10</sup> With regard to § 103, the parties also dispute whether the “for attaching” recitation would have been obvious in view of Grinfas. Pet. 35–36; PO Resp. 33–34. However, for reasons discussed below, we do not reach Petitioner’s contentions under § 103. *Infra* Sec. II.D.6.

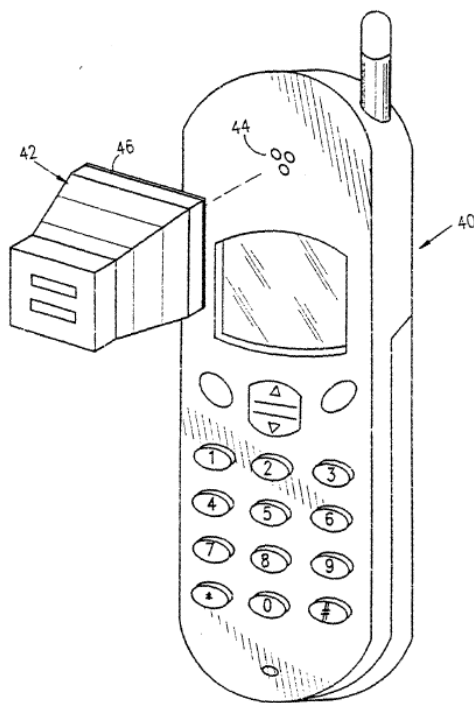

FIG. 3

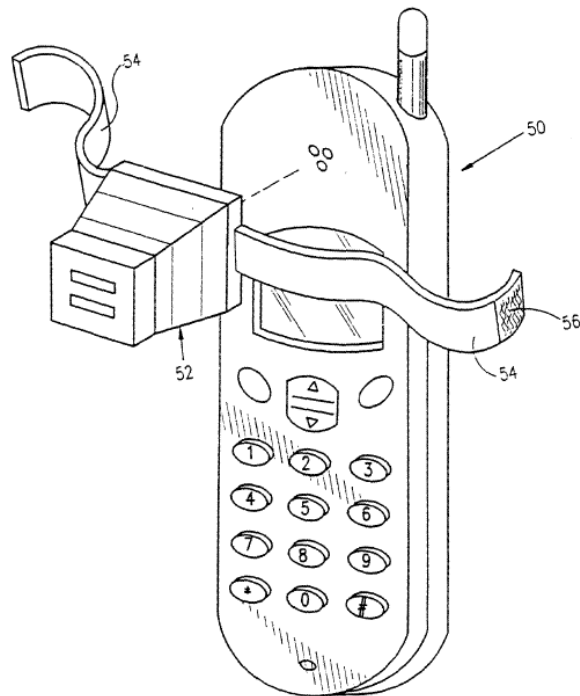

FIG. 4A

Ex. 1005, Fig. 3, 4A. Figure 3 shows cellular telephone 40 and collapsible sound conduit 42, wherein conduit 42 includes adhesive pad 46 for bonding the conduit to earpiece 44 of telephone 40. *Id.* Grinfas discloses that collapsible conduit 42 “may be bonded to an earpiece 44 of telephone 40 by bonding with an adhesive.” *Id.* at 8:6–9. Figure 4A illustrates an alternative securing structure. This figure shows cellular telephone 50 and collapsible sound conduit 52, wherein conduit 52 includes fastenable straps 54 for strapping conduit 52 to telephone 50. *Id.* at Fig. 4A. Grinfas discloses that collapsible sound conduit 52 is fastenable to cellular telephone 50 with straps 54. *Id.* at 8:10–12. Not reproduced herein, Figure 4B of Grinfas “shows collapsible sound conduit 52 strapped to telephone 50.” *Id.* at 16–

17. In yet another alternative embodiment, with reference to Figures 7A and 7B, Grinfas discloses “[t]elephone attachment portion 92 may comprise a bonding pad 99 for attachment to a telephone.” *Id.* at 10:6–7. Based upon these disclosures, we find that Grinfas’s description of structures that secure the collapsible sound conduit to a telephone discloses the structural limitation recited in claim 9, i.e., “a securing element.”

However, as Patent Owner points out, Grinfas describes attaching the collapsible sound conduit to the *front* of the telephone, whereas claim 9 recites a securing element for attaching the socket to the *back* of a portable media player. PO Resp. 28. Petitioner presents two arguments as to why Grinfas nonetheless anticipates the securing element limitation. First, Petitioner argues that the “for attaching” language is not functional, but rather recites an intended use, and as such, it is not entitled to patentable weight. Pet. 26; Reply 6–7. Second, Petitioner argues that the structures disclosed in Grinfas are inherently capable of attaching to the back of a phone or phone case. Pet 26.

As the Federal Circuit has stated, in an apparatus claim, “choosing to define an element functionally, *i.e.*, by what it does, carries with it a risk.” *In re Schreiber*, 128 F.3d 1473, 1478 (Fed. Cir. 1997). This is because “[i]t is well settled that the recitation of a new intended use for an old product does not make a claim to that old product patentable.” *Id.* (citations omitted); *see also ParkerVision, Inc. v. Qualcomm Inc.*, 903 F.3d 1354, 1361 (Fed. Cir. 2018) (“We explained long ago that ‘[a]pparatus claims cover what a device *is*, not what a device *does*.’”); *see also Bettcher Indus., Inc. v. Bunzl USA, Inc.*, 661 F.3d 629, 654 (Fed. Cir. 2011) (“Where all

structural elements of a claim exist in a prior art product, and that prior art product is capable of satisfying all functional or intended use limitations, the claimed invention is nothing more than an unpatentable new use for an old product.”). Similarly, the Federal Circuit has stated that “a prior art reference may anticipate or render obvious an apparatus claim—depending on the claim language—if the reference discloses an apparatus that is reasonably capable of operating so as to meet the claim limitations, even if it does not meet the claim limitations in all modes of operation.”

*ParkerVision*, 903 F.3d at 1361.

For the reasons discussed below, we find that Petitioner has shown persuasively that Grinfas discloses securing structures that are inherently capable of performing the function of attaching the asserted socket to the back of the portable media player. We thus find that Grinfas discloses the limitation “a securing element for attaching the socket to the back of the portable media player or portable media player case.”

We credit Dr. Vallee’s testimony that the securing structures in Grinfas inherently are capable of performing the function of securing the collapsible sound conduit to the back of a telephone. Ex. 1004 ¶ 67. Grinfas describes adhesive pad 46 as an adhesive. Ex. 1005, 8:3–9. We find that this provides sufficient basis for Dr. Vallee to conclude that such adhesive would stick to either side of the telephone. Similarly, Grinfas discloses fastenable straps 54 that include fasteners similar to Velcro at the ends. Ex. 1004, 8:10–17 (describing multiple hook and loop fastener 56). Grinfas discloses using straps 54 with multiple hook and loop fastener 56, and other “conventional fastener[s],” to fasten a sound conduit to a telephone. *Id.*

Also, it is apparent from Figures 4A–B of Grinfas that straps 54 can wrap around telephone 50 and that fastener 56 secures the straps, as well as the sound conduit attached thereto, to the telephone. *Id.* at Figs. 4A–B. We find that this provides sufficient basis for Dr. Vallee to conclude that Grinfas’s straps and fastener could fasten the sound conduit to either side of a telephone, back or front. Based on the foregoing, we find that the securing structures in Grinfas inherently are capable of performing the function of attaching the asserted socket, i.e., collapsible sound conduit 80, to the back of the asserted portable media player, i.e., telephone.

Patent Owner does not dispute Dr. Vallee’s assertion that Grinfas’s securing elements are capable, inherently, of attaching the collapsible sound conduit to the back of a telephone. Indeed, during the oral hearing, Patent Owner’s counsel took no position on the matter, and argued that the issue is not whether Grinfas’s securing structures would adhere the conduit to the back of a phone, but rather is whether Grinfas discloses attaching the conduit to the back of a phone. Tr. 44:12–46:9. Therefore, Patent Owner’s argument is not about whether Grinfas’s securing structures are capable of attaching a conduit to the back of a phone, but rather is about whether Grinfas discloses the function of attaching to the back of a phone. Patent Owner argues that Dr. Vallee’s declaration failed to provide evidence that the claimed *function* is necessarily present in Grinfas, and that his testimony, without (additional) evidence is insufficient to establish inherency. PO Resp. 28–29 (citing *Continental Can Co. USA, Inc. v. Monsanto Co.*, 948 F.2d 1264, 1268 (Fed. Cir. 1991); *S. Clay Prods., Inc. v. United Catalysts, Inc.* 43 Fed. App’x 379, 888 (Fed. Cir. 2002)). We disagree that Petitioner

has failed to establish inherency. In particular, we disagree that Petitioner, or Dr. Vallee, is required to show the claimed function is actually performed or must be performed.

Patent Owner argues that the “for attaching the socket to the back” of a portable player media or case language is entitled to patentable weight (and thus Grinfas must disclose not only that the securing element is capable of being attached to the back of the phone but that it actually is attached to the back of the phone) because, according to Patent Owner, this language recites a fundamental characteristic without which the invention would be of little use. Sur-Reply 7–9. However, Patent Owner does not explain why the placement of the socket on the back, as opposed to some other portion, of a portable media player is fundamental to the claimed invention. *See generally id.* We disagree that the language at issue recites a fundamental characteristic without which the invention would be of little use. Sur-Reply 9.

The '031 patent does not purport to use a novel securing structure, nor describe any feature or characteristic of the securing structures as being specific to attaching to the back, as opposed to some other portion, of a portable media player or case. The '031 patent describes snap-fit elements to attach the accordion, which forms part of the socket, to the portable media player case. Ex. 1001, Fig. 4A, 6:2–3 (describing accordion male snap-fit 13 that engages with socket-board female snap-fit element 16), Fig. 2, 5:33–35 (describing male snap-fit portion 13 on accordion 2 for attachment to socket-board female snap-fit 16 of portable media player case 100). The '031 patent also describes attaching the socket to portable media player 200 by

way of a suction cup, attached to the socket, using tape 33. *Id.* at 7:9–17, Figs. 12A–B. We find nothing to indicate that the disclosed structure, i.e., a suction cup with tape on one end, is specific to attaching a socket to the back of a player or case, as opposed to some other part of the player or case, or that the suction cup and tape provide a structure that is novel. Similarly, we find nothing to indicate that male and female snap-fit structures are either novel or specific to attaching a socket to a particular part of a player or case.

Furthermore, we disagree with Patent Owner that the “for attaching the socket to the back” of a portable player media or case language recites a fundamental characteristic without which the invention would be of little use. Sur-Reply 9. The Specification describes a need in the art for a portable media player case that has extending sockets that can perform a multitude of functions without adding significantly to the effective size of the player. Ex. 1001, 1:12–31. The goal of minimizing the effective size of the player is achieved by using extending elements, called “accordions,” that may collapse in order to save space. *Id.* There is no indication that placement of the socket on the back, as opposed to some other part, of the player or case bears on the effective size of the player. Moreover, the Specification indicates the invention would be useful when attached to the media player or case generally, but does not specify attachment to the back as a requirement. *Id.* at 1:35–45. In particular, in stating that the invention is directed to a portable media player case including an extending socket for serving a function or functions, the Specification does not limit the function(s) to those requiring the socket to be placed on the back of a portable media player case. *Id.*; *see also id.* at 1:17–31. The Specification

provides a non-limiting list of functions, and notes the invention includes embodiments in which the socket is used only for one function. *Id.* at 1:35–45; *see also id.* at 1:17–31. The function(s) include(s) “storing headphone cords and preventing the cords from tangling, forming stand legs, forming gaming grips, clipping to belts, waistbands and shirt pockets, forming legs for wedging players that are phones between the shoulder and ear, and forming a grip that allows a user to securely hold and manipulate the player with one hand.” *Id.* at 1:35–44. This description does not mention attachment to the back of the player or case as a requirement in order to achieve one or more of these functions. Storing headphone cords and preventing cords from tangling, for example, does not specifically require securing the socket to the back, as opposed to some other side, of a portable media player or case. For the foregoing reasons, the Specification does not support the assertion that the invention would be of little use if the socket were attached to a portion of the portable media player or case other than the back portion.

Furthermore, nothing in the file history indicates that attaching the socket to the back of the phone is critical either to the claimed invention or to patentability. *See, e.g.*, Ex. 1003, 90–100 (non-final Office Action), 72–81 (Applicant Amendment and Remarks in response to non-final Office Action). There is neither discussion nor a claim amendment relating to attachment to the back of a media player or case. *See id.*

Thus, neither the Specification nor the file history support Patent Owner’s argument that attaching a socket *to the back* of the portable media player or case is fundamental to the claimed invention. Indeed, Patent

Owner's argument is not that the securing structures in the '031 patent are novel, or that they include features or characteristics specific to attaching to the back of a portable media player or case. *See generally* PO Resp. 29–30. Rather, Patent Owner's argument amounts to one of use, i.e., that the alleged novelty is how the securing structures are used. *See generally id.*; *see generally* Sur-Reply 9. However, as we discussed above, neither the Specification nor the file history require attachment to the back, as opposed to some other portion, of the media player or case in order for the invention to be useful.

For the foregoing reasons, because Grinfas discloses a securing element inherently capable of being attached to the back of a portable media player, we find that Grinfas discloses the securing element limitation.

iii. *“an accordion forming a tapered shape connected to the securing element, the accordion capable of extending outward generally along its axis from the portable media player and retracting back toward the portable media player by collapsing generally along its axis”*

Claim 9 also recites that the socket comprises “an accordion forming a tapered shape connected to the securing element, the accordion capable of extending outward generally along its axis from the portable media player and retracting back toward the portable media player by collapsing generally along its axis.” As we discussed above, we interpret the term “accordion” as “a structure that has hinges, such as flexural hinges or flexural membranes, that fold so as to facilitate extending/expanding and collapsing of the accordion.” *Supra* Sec. II.C.1.c. Moreover, we reject Patent Owner's argument that an “accordion” must have zig-zags in the shape of accordion

bellows, and that the claims require the “accordion” to maintain zig-zags in the shape of accordion bellows in an expanded state. *Supra* Sec. II.C.1.d.

Petitioner identifies collapsible conduit 80, which includes resilient portions 82 and recesses 84, as embodied in Figures 7A–B of Grinfas, as disclosing the “accordion” limitation. Pet. 27–28.

We find, and there is no dispute, that conduit 80, comprised of resilient portions 82 and recesses 84, has a tapered shape and is capable of extending and retracting along its axis, as can be seen in Figures 7A–B. *See, e.g.*, PO Resp. 25 (Grinfas “has an ‘extended state when in use,’” and “a ‘collapsed state when not in use,’” “Figs. 7A and 7B (relied on in the Petition) depict ‘respective extended and collapsed states’ of an embodiment of the sound conduit 80”) (citing Ex. 1005, Abstract, 1:18–19, 5:4–7, 9:9–10:7, Figs. 7A–B). Figure 7A illustrates collapsible sound conduit 80 in an extended configuration, and Figure 7B illustrates the conduit in a collapsed configuration, wherein the extending and collapsing is shown to be along the conduit’s axis. Ex. 1005, 9:9–12, Figs. 7A–B. Also, as can be seen in Figure 7A, sound conduit 80 forms a tapered shape.

Moreover, Petitioner persuasively argues, and we find, that conduit 80, comprised of resilient portions 82 and recesses 84, discloses an accordion. Petitioner argues that recesses 84 form flexural hinges that flex and fold, thus facilitating the collapsing of conduit 80. Reply 4. We find this argument persuasive because Grinfas discloses that recesses 84 “increase the foldability of collapsible sound conduit 80.” Ex. 1005, 9:21–23. Resilient portions 82 are collapsible and foldable onto itself, but may be made of “any elastometric material . . . with a suitable durometer” so that

conduit 80 “has sufficient stiffness or hardness when fully extended.” *Id.* at 9:13–18. Recesses 84 are thinner than resilient portions 82, and form flexural hinges to facilitate folding at the hinges, as can be seen in Figure 7B. Figure 7B shows that in a collapsed configuration, the walls of conduit 80 are folded and form a u-shape at recesses 84. *Id.* at Fig. 7B. For the foregoing reasons, we find that Grinfas’s collapsible sound conduit 80, comprising resilient portions 82 and recesses 84, discloses an accordion.

Patent Owner disputes that sound conduit 80 satisfies the claim language requiring an “accordion” because, according to Patent Owner, sound conduit 80 does not maintain zig-zags in the shape of accordion bellows in an expanded state. PO Resp. 26–28; Sur-Reply 5–7. Patent Owner explains, “Grinfas Figs. 7A and 7B do not teach a tubular structure with pleated folds in its expanded configuration. The walls of the expanded configuration shown in Fig. 7A lack the characteristic ‘zig-zag’ shape of an accordion bellows; that is to say, they are linear, not pleated.” PO Resp. 26. Patent Owner’s arguments do not undermine Petitioner’s showing because such arguments are based on an unduly narrow interpretation of the claim that we do not adopt. *Supra* Sec. II.C.1.d.

For the foregoing reasons, we find that Grinfas discloses “an accordion forming a tapered shape connected to the securing element, the accordion capable of extending outward generally along its axis from the portable media player and retracting back toward the portable media player by collapsing generally along its axis.”

*iv. Conclusion*

For the reasons discussed in detail above, we determine that Petitioner has demonstrated, by a preponderance of the evidence, that claim 9 is anticipated by Grinfas.

*b. Claim 10*

Claim 10 depends from claim 9, and further recites “[t]he socket of claim 9 wherein the accordion comprises rigid walls interspersed with flexural hinges.” Ex. 1001, 8:5–6. Petitioner argues persuasively, and we agree, that Grinfas’s resilient portions 82 disclose rigid walls and Grinfas’s recesses 84 disclose flexural hinges. Pet. 28–29. Grinfas explains that walls 82 may be made of any elastometric material having “sufficient stiffness or hardness when fully extended,” and that “[s]tiffeners or a stiffening material (not shown) may be integrally molded in the elastometric material . . . to achieve the required stiffness or hardness.” Ex. 1005, 9:15–21. Grinfas explains that recesses 84 increase the foldability of collapsible sound conduit 80, and as we discussed above, *supra* Sec. II.D.5.a.iii, these recesses form flexural hinges. Figures 7A–B shows that walls 82 are interspersed with recesses 84. Based on Petitioner’s argument and disclosure in Grinfas such as that noted above, we find that Grinfas discloses the recitation of claim 10.

For the foregoing reasons, we determine that Petitioner has demonstrated, by a preponderance of the evidence, that claim 10 is anticipated by Grinfas.

*c. Claim 11*

Claim 11 depends from claim 10 and further recites “[t]he socket of claim 10 wherein the tapered shape comprises a cone shape constructed and arranged such that the walls fold generally parallel to the axis of the accordion when the accordion is collapsed.” Ex. 1001, 8:7–10. As we discussed above, we interpret the terms “cone” and “cone shape constructed and arranged such that the walls fold generally parallel” as including structures that have circular and other shaped bases and cross-sections. *Supra* Sec. II.C.2.

Petitioner argues persuasively that Figure 7A of Grinfas, which illustrates a tapered-shaped sound conduit 80, shows a cone shape constructed and arranged such that the walls fold generally parallel to the axis of the accordion when the accordion is collapsed. Pet. 29 (citing Ex. 1005, Fig. 7B; Ex. 1004 ¶ 73). Dr. Vallee testifies that it is unclear whether Grinfas’s Figure 7A embodiment (which is only shown in cross section) has a square or a circular base, but that it is reasonable to infer that it has any of the bases shown in Figures 2–6 (square) or Figures 9–12 (circular). Ex. 1004 ¶ 73. However, Petitioner points out that even if collapsible sound conduit 80, shown in Figures 7A–B, has a square base and cross-sections, it would still be a cone shape under the term’s plain and ordinary meaning. Reply 7–8. We are not persuaded that the sound conduit in Figure 7A inherently discloses a circular cone. Figure 7 depicts a particular structure comprising resilient portions 82 interspersed with recessed portions 84 to increase foldability. Ex. 1005, 9:13–23. In contrast, Figures 9–12 (which depict circular bases) are described as using telescoping sections as a means

of collapsing the conduit. *Id.* at 10:23–11:22. Petitioner and Dr. Vallee do not explain sufficiently why one would have inferred that the structure illustrated in Figure 7 of Grinfas, which relies on thinner and thicker wall portions to collapse, would have had a circular base like the embodiments illustrated in Figures 9–12. Nonetheless, because we interpret the term “cone” to include structures having non-circular bases and cross-sections, we find that Grinfas discloses the “cone” limitation.

Patent Owner’s arguments are premised on the assertion that the terms “cone” and “cone shape constructed and arranged such that the walls fold generally parallel” are limited to structures having circular bases and circular cross-sections. PO Resp. 30–32; Sur-Reply 9–11. Patent Owner argues that the collapsible sound conduit shown in Figure 7A has a square base and cross-sections. PO Resp. 30–32; Sur-Reply 9–11. However, because we interpret the term “cone” to include structures having non-circular bases and cross-sections, Patent Owner’s arguments do not undermine Petitioner’s showing.

For the foregoing reasons, we determine that Petitioner has demonstrated, by a preponderance of the evidence, that claim 11 is anticipated by Grinfas.

*d. Claim 16*

Independent claim 16 is a method claim that includes recitations similar to those in independent claim 9. For “attaching a socket including an accordion forming a tapered shape and having walls interspaced with flexural hinges to a portable media player,” as recited in claim 16, Petitioner persuasively argues that Grinfas’s conduit 82, as shown in Figure 7,

discloses a socket including a tapered accordion having walls interspaced with flexural hinges to a portable media player. Pet. 29. For “selectively extending the socket by unfolding the accordion generally along its axis,” as recited in claim 16, Petitioner persuasively argues that conduit 82 may be selectively extended along its axis as required by this claim. *Id.* at 30. As we discussed above, Figure 7A of Grinfas illustrates an extended configuration, and Figure 7B illustrates a collapsed configuration, wherein the extending occurs along conduit 82’s axis. Claim 16 also recites “selectively retracting the socket by folding the accordion generally along its axis such that the walls fold next to each other.” Petitioner persuasively argues that Figure 7B of Grinfas, which depicts a collapsed configuration in which resilient portions 82 (asserted to be walls) are folded next to each other, discloses this limitation. *Id.* (citing Ex. 1004 ¶ 77; Ex. 1005, Abstract, 9:9–10:5, Fig. 7B). Patent Owner raises the same arguments for claim 16 that it raises for claim 9, and we find them unavailing for the same reasons as discussed above for claim 9. PO Resp. 24–33. For the foregoing reasons, we find that Grinfas discloses the limitations of claim 16.

For the foregoing reasons, we determine that Petitioner has demonstrated, by a preponderance of the evidence, that claim 16 is anticipated by Grinfas.

*e. Claim 17*

Claim 17 depends from claim 16, and further recites “[t]he method of claim 16 wherein the retracting step folds the walls into an orientation such that the walls are generally parallel to the axis of the accordion.” Ex. 8:34–36. Petitioner relies on Figure 7B of Grinfas, which depicts a retracted

configuration in which resilient portions 82 (asserted to be walls) are generally parallel to the axis of conduit 80. Pet. 30 (citing Ex. 1004 ¶ 78; Ex. 1005, Fig. 7B).

Patent Owner raises the same arguments for claim 17 that it raises for claim 9, and we find them unavailing for the same reasons as discussed above for claim 9. PO Resp. 24–33. For the foregoing reasons, we find that Grinfas discloses the limitations of claim 17.

For the foregoing reasons, we determine that Petitioner has demonstrated, by a preponderance of the evidence, that claim 17 is anticipated by Grinfas.

#### *6. Asserted Obviousness Over Grinfas*

Petitioner also provides argument, contingent on our finding the recitation “for attaching the socket to the back of the portable media player or portable media player case” to be a functional limitation of claim 9, that claims 9–11 would have been obvious over Grinfas. Pet. 35–36.

As we discussed above, we find claims 9–11, 16, and 17 of the ’031 patent to be unpatentable as anticipated by Grinfas, and in particular, we find Grinfas discloses the recitation “for attaching the socket to the back of the portable media player or portable media player case.” *See supra* Section II.D.5. Petitioner’s obviousness arguments address only a subset of these claims, i.e., claims 9–11, and relate to whether the “for attaching” recitation, which we already find is disclosed in Grinfas, would have been obvious to a skilled artisan. We therefore need not, and do not, reach the patentability of claims 9–11 as obvious over Grinfas. *See In re Gleave*, 560 F.3d 1331, 1338 (Fed. Cir. 2009) (“Therefore, we affirm the Board’s rejection of claims 1, 4,

15, and 18–21 of the '493 application under § 102(b). We need not reach the § 103 obviousness rejection.”).

*7. Asserted Anticipation by Karmatz*

Petitioner asserts claim 9 of the '031 patent is unpatentable under 35 U.S.C. § 102(e) as anticipated by Karmatz. Pet. 36–41.

We are not persuaded Petitioner has shown Karmatz discloses “[a]n *accordion* forming a tapered shape connected to the securing element,” as recited in claim 9. Ex. 1001, 7:65–66 (emphasis added). With regard to this recitation, Petitioner states only that “Karmatz discloses an accordion 120 having a tapered shape that may be affixed to the handheld device via the securing element.” Pet. 38. Petitioner cites paragraphs 29 and 43 and Figure 20 of Karmatz. *Id.* (citing Ex. 1006 ¶¶ 29, 43, Fig. 20). The cited portions of Karmatz disclose extension 120, asserted by Petitioner to be an accordion, as being “a single piece or a series of telescopic pieces 124 that expand/collapse together as the grip device moves from the open to the closed position.” Ex. 1006 ¶ 43. This description is consistent with Figure 20, which depicts telescoping structure 120. Petitioner offers no explanation as to why a telescoping structure with annular pieces that slide over one-another would be considered an “accordion,” as recited in claim 9. Dr. Vallee’s testimony, upon which Petitioner relies, adds nothing to Petitioner’s contentions. He states, without evidence or explanation, that “Karmatz discloses various extensions 120, including one extension 120 shown in Figure 20 that is an accordion.” Ex. 1004 ¶ 83.

Petitioner has not shown the telescoping structure it relies upon in Karmatz is an “accordion.” As we discussed above, we interpret the term

“accordion” as “a structure that has hinges, such as flexural hinges or flexural membranes, that fold so as to facilitate extending/expanding and collapsing of the accordion.” *Supra* Sec. II.C.1.c. Petitioner has not shown that the telescoping structure in Karmatz has hinges.

For the foregoing reasons, we determine Petitioner has not demonstrated, by a preponderance of the evidence, that claim 9 is anticipated by Karmatz.

We note that Patent Owner argues Karmatz is not prior art to the '031 patent. PO Resp. 44–62. However, because Petitioner has not demonstrated that Karmatz discloses each and every limitation of claim 9, we need not, and do not, reach the issue of whether Karmatz qualifies as prior art to the '031 patent.

*8. Asserted Obviousness Over Karmatz and Mikol*

Petitioner asserts claims 9–11, 16, and 17 of the '031 patent are unpatentable under 35 U.S.C. § 103(a) as obvious over the combination of Karmatz and Mikol. Pet. 41–55. In support of its proposed combination of Karmatz and Mikol, Petitioner argues that a person of ordinary skill in the art “would have been inclined to employ the accordion of Mikol with the device of Karmatz.” Pet. 43.

Patent Owner argues that Mikol is non-analogous art to the claimed invention. PO Resp. 63–68; *see also id.* at 63–64 (citing *In re Klein*, 647 F.3d 1343, 1348 (Fed. Cir. 2011)). As we noted above, under *In re Klein*, “[a] reference qualifies as prior art for an obviousness determination under § 103 *only when it is analogous to the claimed invention.*” 647 F.3d at 1348

(emphasis added). “Two separate tests define the scope of analogous prior art”:

(1) whether the art is from the same field of endeavor, regardless of the problem addressed and, (2) if the reference is not within the field of the inventor’s endeavor, whether the reference still is reasonably pertinent to the particular problem with which the invention is involved.

*Id.* (citations omitted). Whether a reference in the prior art is analogous is a question of fact. *In re Clay*, 966 F.2d at 658. For the following reasons, we find Petitioner has not shown that Mikol is analogous art to the claimed invention of the ’031 patent.

*a. Field of Endeavor*

Petitioner has not demonstrated that Mikol is from the same field of endeavor as the ’031 patent. Petitioner’s assertion that Mikol is from the same field of endeavor is based on a misapplication of *Wyers v. Master Lock Co.*, 616 F.3d 1231 (Fed. Cir. 2010). Reply 23–25. Petitioner argues that when a patent incorporates prior art by reference, it integrates into the patent’s field of endeavor the prior art reference’s field of endeavor. *Id.* (citing *Wyers*, 616 F.3d at 1237–38). For reasons set forth below, we disagree.

Patent Owner argues, and we find, that Mikol is not in the same field of endeavor as the ’031 patent. PO Resp. 64–65. The ’031 patent relates to mobile device accessories, “in particular, ‘extending sockets for portable media players,’” whereas Mikol is pertinent to the field of plumbing, in particular structures “well adapted to serve as a pouring spout or other adjustable spout.” *Id.* (quoting Ex. 1009, 1:25–26). Also, Mikol relates to

“tubular structures used for transfer of fluids, which is different from the field of endeavor of the ’031 patent, mobile-device accessories.” *Id.* at 65. Indeed, Mikol states that the invention relates to an adjustable tubular wall structure for “a connection between out of alignment discharge and intake ports or apertures in the plumbing field,” and an adjustable, non-cylindrical wall structure “particularly well adapted to serve as a pouring spout or other adjustable spout, or which is affixed to or connectable to a container.”

Ex. 1009, 1:7–27. The ’031 patent, in contrast, states in the background and summary of invention that the invention relates portable media player cases, and in particular an extendable structure for attaching to a portable media player or case, to perform a multitude of functions, including storing headphone cords, forming stand legs, forming gaming grips, clipping to belts, waistbands and shirt pockets, and forming grips that make it easier to hold and manipulate the player with one hand. Ex. 1001, 1:5–44.

Despite these clearly different fields of endeavor, Petitioner seeks to expand the ’031 patent’s field broadly to include the field of endeavor of a prior art reference, U.S. Patent No. 4,846,510 (“the ’510 patent”), that the ’031 patent incorporates by reference. Reply 23–24 (citing Ex. 1001, 5:39–43). Mikol is a continuation-in-part of the ’510 patent, and Petitioner argues they share the same field of endeavor with each other. Ex. 1009, at [63]; *see also* Reply 24–25 (explaining that Mikol is a continuation-in-part of the ’510 patent). Petitioner asserts that the ’031 patent incorporates portions of the ’510 patent describing “the plumbing field,” “drain systems,” “fluid flow conducting or other ducting purposes,” “plumbing type connection devices,” “hose lengths,” “containers,” and “arms for toy robots.” Reply 24.

Petitioner argues that the '031 patent therefore “integrates the fields identified in the incorporated passages.” *Id.* (citing *Advanced Display Sys., Inc. v. Kent State Univ.*, 212 F.3d 1272, 1282 (Fed. Cir. 2000) (“Kent State”<sup>11</sup>).

We disagree that the field of endeavor of the '510 patent is integrated into the field of endeavor of the '031 patent. Petitioner's argument leads to the absurd result that the field of endeavor of the '031 patent, which clearly relates to media player accessories, also includes plumbing and drain systems, fluid flow and ducting, and the like, even though the '031 patent itself does not discuss plumbing and fluid flow fields. Petitioner cites no legal authority that supports its position. *See, e.g.*, Tr. 27:25–28:8. Petitioner relies on *Kent State* and *Wyers*; however, even Petitioner admits that these cases do not hold that the field of endeavor of a referenced prior art reference is integrated into the field of endeavor of the referencing patent. *Id.* at 28:11–30:18.

*Kent State* explains that “[m]aterial not explicitly contained in a single, prior art document may still be considered for purposes of anticipation if that material is incorporated by reference into the document.” *Kent State*, 212 F.3d at 1282 (citations omitted). However, *Kent State* states that “[t]o incorporate material by reference, the host document must identify with detailed particularity what specific material it incorporates and clearly

---

<sup>11</sup> At the oral hearing, the parties and Board referred to this case as *Kent State*. *See, e.g.*, Tr. 27:4, 28:11, 28:15, 30:16, 31:11. For consistency, herein we refer to the case as *Kent State*.

indicate where that material is found in the various documents.” *Id.* (citations omitted). Nothing in *Kent State* indicates that incorporation by reference of material integrates into a host document the field of endeavor of the reference containing the material.<sup>12</sup> At the oral hearing, Petitioner’s counsel acknowledged that *Kent State* does not address the issue of analogous art, stating that Petitioner introduced *Wyers* for discussion of analogous art. Tr. 28:11–18.

However, *Wyers* does not support Petitioner’s position either. *Wyers* involves a district court’s denial of a motion seeking judgment as a matter of law that certain patent claims would have been obvious. “The ’649 patent” (alternatively referred to as “the seal patent”), claimed an improved locking device with an external seal designed to insulate the locking mechanism of the lock from the ingress of contaminants. *Wyers*, 616 F.3d at 1235. The lower court had determined the field of endeavor to be “locksmithing.” *Id.* at 1238. It was conceded that the prior art included all the claimed features except for the claimed seal. *Id.* at 1236. The issue before the jury, therefore, was whether the defendant “presented clear and convincing evidence that the use of an external flat flange seal would have been obvious.” *Id.* The prior art disclosed padlock seals, which the district court concluded a jury could have found to be outside the scope of relevant art. *Id.* at 1237–1238. The

---

<sup>12</sup> The issue in *Kent State* was whether the magistrate erred in tasking a jury with determining what material was incorporated by reference. *Kent State*, 212 F.3d 1283. The court held it was error because whether and to what extent material has been incorporated by reference into a host document is a question of law. *Id.*

Federal Circuit, however, determined “there is no reason why padlocks should be excluded from the relevant prior art,” noting that the ’649 patent “itself defines its scope broadly, and makes clear that the claims are directed to ‘locking device[s]’ generally.” *Id.* at 1238 (citations omitted).

Accordingly, the Federal Circuit determined that the ’649 patent itself included padlocks within its field of endeavor. *See id.* The court also noted that the ’649 patent refers to “the prior art padlock” in the field of invention, but this observation is in addition to the other evidence and indications in the patent as to the field of endeavor. *Id.* Moreover, contrary to Petitioner’s suggestion, the Federal Circuit did not hold that incorporation by reference integrates the incorporated reference’s field of endeavor into the field of endeavor of the host document.

For the foregoing reasons, we determine that Mikol has not been shown to be in the same field of endeavor as the ’031 patent.

*b. Pertinence to the Particular Problem with Which the Invention is Involved*

Given Mikol is not in the same field of endeavor as the ’031 patent, we turn to whether Mikol is reasonably pertinent to the particular problem with which the ’031 invention is involved. For reasons discussed below, Petitioner has not demonstrated this to be so. Patent Owner argues Mikol is not reasonably pertinent to the problem addressed by the ’031 patent, namely that of providing an accessory that provides the functions discussed at column 1, lines 17 through 31 of the ’031 patent. PO Resp. 65–66; *see also* Ex. 1001, 1:17–31 (describing extending arms of a portable media player case for performing the functions of standing a case on its side,

providing headset management and/or headset storage, acting as gaming grips, and mounting to a belt via a clip).

The '031 patent states, in particular, that a need remains for an extending structure to attach to a media player or case that performs the functions described above “without adding significantly to the effective size of the [media] player.” Ex. 1001, 1:28–31. This is different from the stated problem in Mikol, namely that “a common problem in many fields” arises from the need to connect a drain and a duct opening or port to allow for fluid flow between the two, wherein the drain and opening/port are not aligned. Ex. 1009, 1:28–32. Mikol states that to address this problem, a tubular connector needs some degree of adjustability. *Id.* The '031 patent, therefore, seeks to provide a structure for attaching to a media player that does not add significantly to the effective size of the player, whereas Mikol seeks to provide an adjustable tubular structure that can accommodate fluid flow for connecting drains and/or openings/ports that are not aligned.

Petitioner correctly identifies a problem the '031 patent sought to address, namely that need for a portable media player case and extending socket that performs a multitude of functions without adding significantly to the effective size of the player. Reply 25. However, rather than explain how Mikol addresses the identified problem, Petitioner improperly incorporates by reference the testimony of Dr. Vallee, stating only that “Mikol provides a solution to this problem, as Dr. Vallee detailed in his declaration.” *Id.* (citing Ex. 1004, ¶¶ 89–110); *see* 37 C.F.R. § 42.6(a)(3) (stating “[a]rguments must not be incorporated by reference from one document into another document”). Petitioner leaves to the Board the task of ascertaining,

from nine pages of testimony regarding how the combination of Mikol and Karmatz render obvious claims 9, 10, 11, 16, and 17, what is Petitioner’s argument as to how Mikol addresses the above-identified problem the ’031 patent seeks to solve—a task that we do not undertake. 37 C.F.R. § 42.6(a)(3).

In view of our finding that the ’031 patent seeks to provide a structure that does not add significantly to the effective size of the media player, whereas Mikol seeks to provide an adjustable tubular structure that can accommodate fluid flow for connecting drains and/or openings/ports that are not aligned, and in further view of the Petition’s lack of explanation concerning how Mikol addresses the problem the ’031 patent set out to solve, Petitioner has not shown Mikol is reasonably pertinent to the particular problem with which the invention is involved.

*c. Conclusion*

For the foregoing reasons, we find that Mikol is not analogous art to the ’031 patent. Because Mikol is not analogous art, we find Petitioner’s combination of Mikol with Karmatz to be improper.

For the foregoing reasons, we determine Petitioner has not demonstrated, by a preponderance of the evidence, that claims 9–11, 16, and 17 are unpatentable as obvious over the combination of Karmatz and Mikol.

*9. Asserted Anticipation by Barbera*

Petitioner asserts claim 9 of the ’031 patent is unpatentable under 35 U.S.C. § 102(b) as anticipated by Barbera. Pet. 55–60.

With regard to the recitation in claim 9 that the socket comprises “[a]n accordion forming a tapered shape connected to the securing element,”

Petitioner states only that “Barbera discloses a socket in the form of a tapered accordion 25 including a base plate 11 used for securing the accordion to another device.” *Id.* at 56. Petitioner includes an annotated version of Figure 4 of Barbera in which Petitioner identifies element 25 as an accordion. *Id.* at 57. In support of its assertion, Petitioner relies on Dr. Vallee’s declaration, which repeats the Petition verbatim. *Id.* (citing Ex. 1004 ¶ 114). Petitioner also cites the following disclosure in Barbera: “Alternatively the bellows, as shown in Fig. 4, may be shaped conically whereby successively convolutions are progressively increased in diameter, going from the top to the bottom.” *Id.* at 56 (citing Ex. 1010, 3:2–5). Neither Petitioner, nor Dr. Vallee, explain how this disclosure supports Petitioner’s assertion. Petitioner does not explain whether this is cited to support the assertion that element 25 is an accordion, or that it forms a tapered shape, or that it is secured to a connecting element, all of which are required by claim 9.

Patent Owner responds that the structure in Barbera identified by Petitioner as an accordion “absorbs shock and vibrations and provides damping, but it does not collapse.” PO Resp. 72. Because it does not collapse, according to Patent Owner, the structure is not an accordion. *Id.* at 71–72. Patent Owner argues the shock absorption isolator in Barbera is “constructed of metal and is used for absorbing shock ‘to protect the apparatus from such transient forces.’” *Id.* at 72 (quoting Ex. 1010, 1:36–37). According to Patent Owner, the structure is not designed to collapse, but instead “is designed to ‘have properties of high energy absorption and low resilience’” and “allows only for ‘small deflections,’ and ‘stiffness

increases as the deflection becomes greater.” *Id.* (quoting Ex. 1010, 1:39–40, 3:10–13).

Petitioner has not shown element 25 in Barbera is an accordion “capable of extending outward generally along its axis from the portable media player and retracting back toward the portable media player by collapsing generally along its axis.” Petitioner asserts that “accordion 25 is capable of extending outward generally along its axis and retracting back by collapsing generally along its axis,” without providing any further explanation. Pet. 57. Petitioner cites to the testimony of Dr. Vallee, which is nothing more than the same conclusory assertion in the Petition verbatim. *Id.* (citing Ex. 1004 ¶ 115<sup>13</sup>). Petitioner also cites to disclosure in Barbera that describes compression of the bellows resulting in compression of air contained therein, and that forced vibrations will cause the metal bellows to have motion in the vertical, horizontal, and transverse directions. *Id.* (citing Ex. 1010, 2:50–65). Neither Petitioner, nor Dr. Vallee, provide evidence or argument that the motion described in Barbera amounts to extending outward and retracting back by collapsing along an axis. As Patent Owner points, the bellows depicted in Figure 4 of Barbera are for shock absorption and isolation, and thus Barbera discloses its bellows allow for only *small* deflections. PO Resp. 72 (quoting Ex. 1010, 1:39–40, 3:10–13). Given the teaching of allowing for only small deflections, we are not persuaded that the bellows of the shock absorption isolator in Figure 4 is capable of

---

<sup>13</sup> The Petition mistakenly cites paragraph 114 of Dr. Vallee’s declaration, rather than paragraph 115.

extending outward generally along its axis and retracting back by collapsing generally along its axis.

For the foregoing reasons, we determine Petitioner has not demonstrated, by a preponderance of the evidence, that claim 9 is unpatentable as anticipated by Barbera.

*E. Patent Owner's Motions to File Under Seal*

Patent Owner moves for entry of a Protective Order (Ex. 2090), which “differs from the Default Protective Order in that it includes a second level of confidentiality designation, ‘HIGHLY CONFIDENTIAL—ATTORNEYS’ EYES ONLY.’” Paper 22, 1; *see also* Ex. 2074 (redlined version of the Default Protective Order showing changes). Patent Owner also moves for leave to file under seal Ex. 2062, a confidential version of Patent Owner’s Response (Paper 17) and Dr. Barnett’s second declaration (Ex. 2062), and portions of Dr. Barnett’s deposition transcript (Ex. 1016). Paper 22; Paper 31. Petitioner opposes these motions. Paper 20; Paper 36.

Except as otherwise ordered, the record of an *inter partes* review trial shall be made available to the public. *See* 35 U.S.C. § 316(a)(1); 37 C.F.R. § 42.14. Motions to seal may be granted for good cause; until the motion is decided, documents filed with the motion shall be sealed provisionally. *See* 37 C.F.R. §§ 42.14, 42.54(a). The moving party bears the burden of showing that there is good cause to seal the record. *See* 37 C.F.R. § 42.20(c). Also, relevant to these motions, the Trial Practice Guide Update states:

No protective order shall apply to this proceeding until the Board enters one. If either party files a motion to seal

before entry of a protective order, a jointly proposed protective order shall be filed as an exhibit with the motion. The Board encourages the parties to adopt the Board's default protective order if they conclude that a protective order is necessary. *See* Practice Guide, App'x B (Default Protective Order). If the parties choose to propose a protective order deviating from the default protective order, they must submit the proposed protective order jointly along with a marked-up comparison of the proposed and default protective orders showing the differences between the two and explain why good cause exists to deviate from the default protective order.

The Board has a strong interest in the public availability of trial proceedings. Redactions to documents filed in this proceeding should be limited to the minimum amount necessary to protect confidential information, and the thrust of the underlying argument or evidence must be clearly discernible from the redacted versions. We also advise the parties that information subject to a protective order may become public if identified in a final written decision in this proceeding, and that a motion to expunge the information will not necessarily prevail over the public interest in maintaining a complete and understandable file history. *See* Practice Guide 48,761.

Trial Practice Guide Update, 83 Fed. Reg. 39,989 (Aug. 13, 2018) ("Practice Guide August 2018 Update").<sup>14</sup>

The information Patent Owner seeks to seal includes PopSockets' sales data by year from 2014 to 2018 (Ex. 2016 ¶¶ 180–182), and a

---

<sup>14</sup> Available at [https://www.uspto.gov/sites/default/files/documents/2018\\_Revised\\_Trial\\_Practice\\_Guide.pdf](https://www.uspto.gov/sites/default/files/documents/2018_Revised_Trial_Practice_Guide.pdf).

MarkMonitor market place report including over 100 pages of detailed PopSockets' sales data (Ex. 2062). Patent Owner also seeks to seal portions of the Patent Owner Response, Dr. Barnett's second declaration, and Dr. Barnett's deposition transcript, that include such information.

Patent Owner asserts the HIGHLY CONFIDENTIAL—ATTORNEYS' EYES ONLY designation is warranted because certain disclosed information would provide Petitioner with "direct insight into Patent Owner's closely held strategic business considerations and legal positions. Such access would severely hinder Patent Owner's ability to fairly compete in the market and participate in arm's length settlement negotiations with Petitioner." Paper 22, 2. Patent Owner avers that the asserted highly confidential information has never, to the best of Patent Owner's knowledge, been made public. *Id.*

Petitioner replies that the information Patent Owner seeks to protect is "information that [Patent Owner] has already willingly placed in the public domain." Paper 20, 1, 3–6. Petitioner argues that Patent Owner publicized some, but not all, of the information via an article in Forbes magazine and a profile in Inc.5000. *Id.* at 4–5 (citing Ex. 2089, Ex. 2014). Patent Owner responds that the information that was made public, which includes revenue estimates and rounded figures, differs from the information it seeks to seal, which provides future projections and more detailed information, such as numbers of units sold, which revenue numbers do not convey. *See generally, e.g.*, Paper 27. Upon review of the parties' arguments, and underlying exhibits and papers, we find that the information Patent Owner seeks to seal differs from the information Petitioner identifies as having been

made public. Moreover, we determine Patent Owner has shown good cause for an order protecting it from disclosure of the designated information, which contains financial information that Patent Owners avers is confidential and would provide insight into closely held strategic business considerations. 37 C.F.R. § 42.54.

We also find that maintaining confidentiality is not outweighed by the public's interest. Patent Owner relies on the designated information to show secondary considerations of non-obviousness as to the following grounds: 1) obviousness over Grinfas, and 2) obviousness over Karmatz and Mikol. *See generally, e.g.*, PO Resp. 39–44, 68. However, for reasons discussed above, we do not reach Petitioner's assertion of obviousness over Grinfas. *Supra* Sec. II.D.5. Nor do we reach the secondary considerations raised by Patent Owner as to the combination of Grinfas and Mikol because, for reasons stated above, Petitioner has not shown Mikol to be analogous art. *Supra* Sec. II.D.7. Because we do not rely on the information designated as confidential in this Final Decision, Patent Owner's desire to keep this information confidential is not outweighed by the public interest in maintaining a complete and understandable record of this proceeding.

For the foregoing reasons, we enter the modified proposed Protective Order (Ex. 2090), and we grant Patent Owner's motions to file under seal (Paper 22; Paper 31).

As set forth in the Board's Trial Practice Guide, confidential information that is sealed subject to a protective order ordinarily will become public 45 days after final judgment in a trial. Office Patent Trial Practice Guide, 77 Fed. Reg. 48,756, 48,761 (Aug. 14, 2012) ("Trial Practice

Guide”). A party seeking to maintain confidentiality of information may file a motion to expunge the information before it becomes public. *Id.*; *see also* 37 C.F.R. § 42.56.

*F. Petitioner’s Motion to Exclude*

As we noted above, Petitioner filed a Motion to Exclude Evidence Under 37 C.F.R. § 42.64(c), seeking to exclude Exhibits 2008, 2009, 2014, 2023, and 2088, and any and all argument or testimony in the record that rely on one or more of these exhibits. Paper 40 (“Motion to Exclude”); *see also* Paper 43 (reply to Patent Owner’s opposition to Petitioner’s Motion to Exclude). Patent Owner opposes the motion. Paper 41.

In rendering this Final Decision, we do not rely on these exhibits, and argument and testimony relying on such exhibits. The material Petitioner seeks to exclude relates to testing performed by Patent Owner’s declarant, Mr. Babcock, offered by Patent Owner to support a date of invention that precedes the ’031 patent’s filing date. Mot. to Exclude 2–13. The alleged earlier invention date goes to the issue of whether Karmatz qualifies as prior art to the ’031 patent. PO. Resp. 47–62. Patent Owner asserts that the ’031 patent was reduced to practice by August 17, 2010, or in the alternative, was conceived by that date and reduced to practice by November 16, 2010. *Id.* at 47. However, the only prior art ground under which unpatentability has been shown is based on Grinfas, a UK patent application published on February 18, 1998—over a decade before Patent Owner’s alleged invention date. Ex. 1005. Accordingly, we need not, and do not, determine the merits of Patent Owner’s alleged date of invention. As such, we do not rely on the

material Petitioner seeks to exclude, and Petitioner's Motion to Exclude is dismissed as moot.

*G. Constitutionality Argument*

Patent Owner contends the Institution Decision is unconstitutional under the appointments clause of Article II of the Constitution, and should be dismissed, on the grounds that Administrative Patent Judges are principal officers who must be appointed by the President and confirmed by the Senate. PO Resp. 72.

Petitioner responds that this question is pending before the Federal Circuit, and that Board panels have declined to consider this issue. Reply 26.

In this Decision, we decline to consider the merits of Patent Owner's constitutional challenges. *See Riggin v. Office of Senate Fair Employment Practices*, 61 F.3d 1563, 1569 (Fed. Cir. 1995). We note, however, that the issue is presently before the Federal Circuit in *Polaris Innovations Limited v. Kingston Technology Company* (No. 2018-1768).

III.CONCLUSION

For the foregoing reasons, we determine Petitioner has demonstrated, by a preponderance of the evidence, that claims 9–11, 16, and 17 of the '031 patent are unpatentable as anticipated by Grinfas. We do not reach Petitioner's contentions that claims 9–11 would have been obvious over Grinfas, *supra* Sec. II.D.6, and Petitioner has not demonstrated unpatentability under any other ground raised in the Petition, *supra* Secs. II.D.7–9.

IV. ORDER

In consideration of the foregoing, it is hereby  
ORDERED that claims 9–11, 16, and 17 of the '031 patent are  
unpatentable;

FURTHER ORDERED that Patent Owner's Motion to File  
Under Seal and Enter Proposed Protective Order (Paper 22) and Patent  
Owner's Second Motion to File Under Seal (Paper 31) are *granted*;

FURTHER ORDERED that the proposed Protective Order  
(Paper 2090) is hereby entered in this proceeding;

FURTHER ORDERED that Petitioner's Motion to Exclude Evidence  
under 37 C.F.R. § 42.64(c) (Paper 40) is dismissed as moot; and

FURTHER ORDERED that because this is a final written decision,  
parties to the proceeding seeking judicial review of the decision must  
comply with the notice and service requirements of 37 C.F.R. § 90.2.

IPR2018-00497  
Patent 8,560,031

PETITIONER:

Steven Auvil  
Bryan Jaketic  
SQUIRE PATTON BOGGS LLP  
[steven.auvil@squirepb.com](mailto:steven.auvil@squirepb.com)  
[bryan.jaketic@squirepb.com](mailto:bryan.jaketic@squirepb.com)

PATENT OWNER:

Michael Fleming  
IRELL & MANELLA LLP  
[mflaming@irell.com](mailto:mflaming@irell.com)

Michael Furmanek  
Michael Weiner  
MARSHALL GERSTEIN & BORUN LLP  
[mfurmanek@marshallip.com](mailto:mfurmanek@marshallip.com)  
[mweiner@marshallip.com](mailto:mweiner@marshallip.com)